

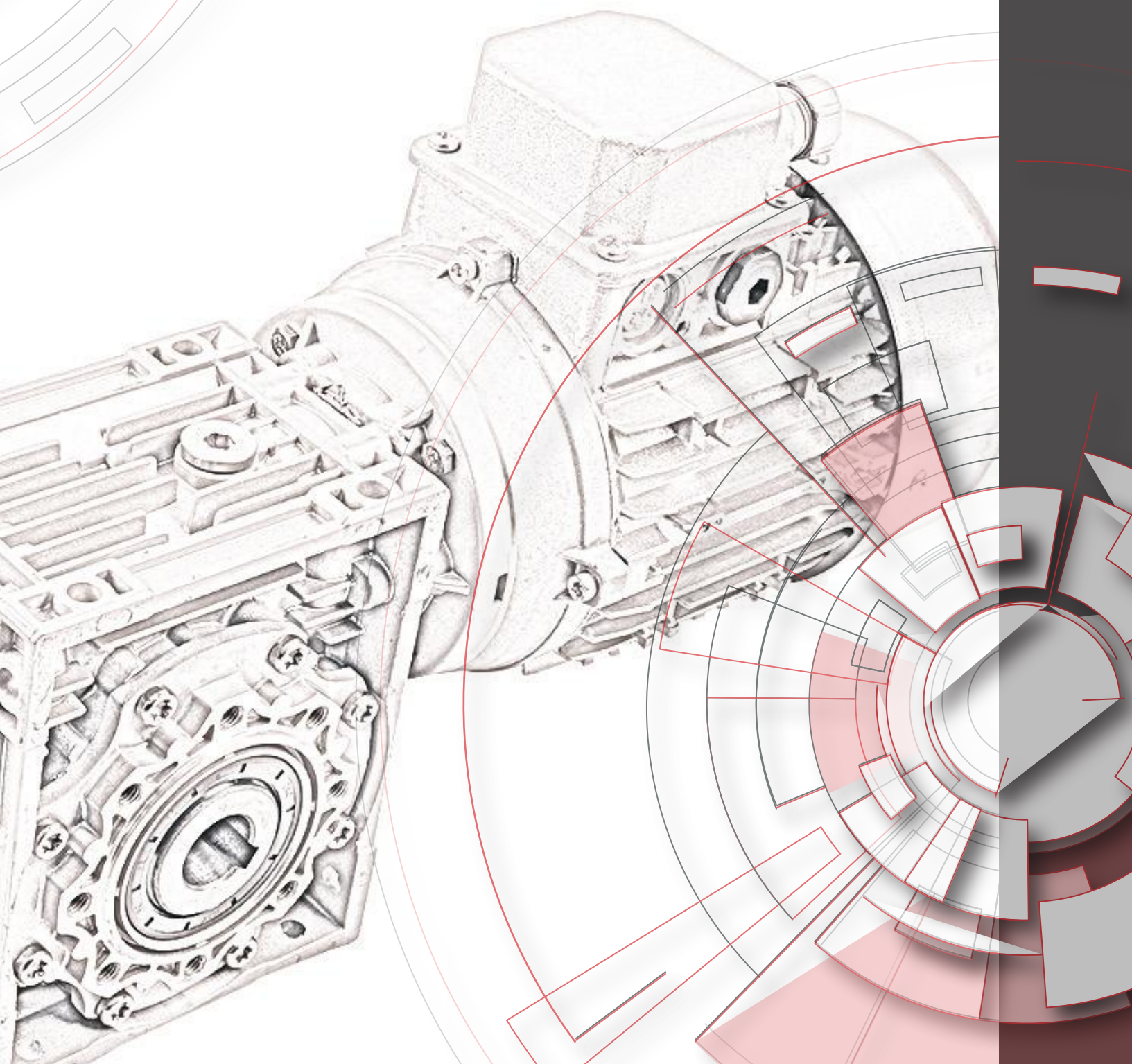

GEMOTEG
GmbH & Co. KG
Drives + Systems®



Schneckengetriebe | Verstellgetriebe | Elektromotoren
Worm gears | Speed variators | Electric motors

Drives & Systems

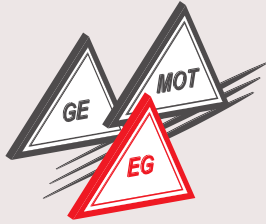

Schneckengetriebe

Worm gearboxes

Aluminium-Gehäuse aus einem Stück gefertigt

Single-piece aluminum alloy housing

Vacuum impregnated (MIL-STD 276) for protection and sealing. No secondary finish required but readily accepts paint. Combines light weight with high tensile strength. Precision machined for alignment of bearings and gearing.

Getriebeeingang

Flange

Fully modular to IEC and compact integrated motor. NEMA C flange.

Eingangswelle & Schneckenwelle aus legiertem Stahl

Single piece alloy steel input shaft and worm shaft

High helix angle worm is case-hardened (Rc 58-60), ground, teeth are profiled and radiused, for noise reduction and enhanced efficiency.

Schneckenwelle mit großen Kugellagern und Qualitätsdichtungen

Oversized bearings

Oversized bearings support positively-retained, high speed shaft for higher shock load capacity - ideal for frequent starting and reversing application. Premium, high temperature seals each end.

Schneckenräder bronzelegiert

Bronze alloy worm gears

Is centrifugally cast onto an iron hub for maximum strength and superior life.

Premium NBR- und FPM-Abtriebswellendichtringe

Premium NBR or Viton output seals

Groß dimensionierte Kugellager

Oversize bearing

For radial load capability and maximum hollow output shaft diameter.

Montage einer Abtriebshohlwelle

Standard hollow output shaft mounting

Reduces total drive envelope size, weight and cost. Single and double solid output shaft is available.

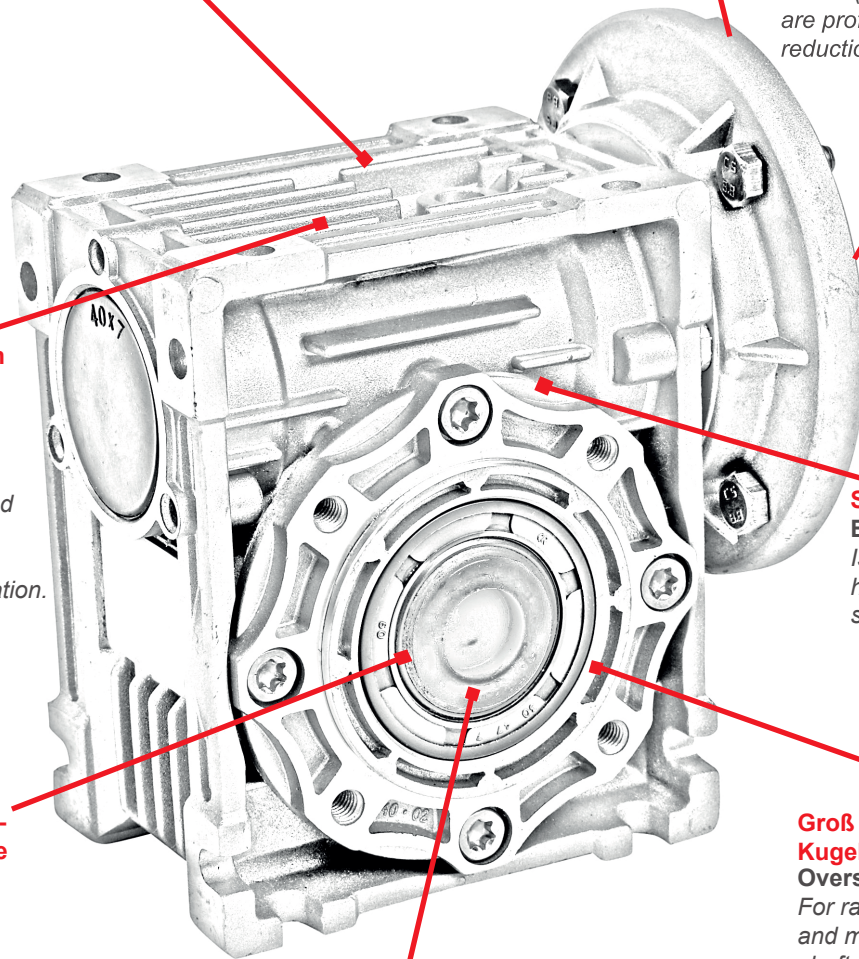

1. Produktinformationen - *Product information*

1.1 Betriebsfaktor – *Service factor*

Der Betriebsfaktor (f.s.) hängt von den Betriebsbedingungen ab, für die der Antrieb eingesetzt wird. Folgende Parameter sind für die Auswahl des richtigen Servicefaktors zu berücksichtigen:

- Belastungsart der angetriebenen Maschinen A - B - C
- tägliche Betriebsdauer: Stunden/Tag
- Anlauffrequenz: Anläufe/Stunde (*)

LAST: A - gleichförmig, $f_a = 0,3$
B - mittlere Überlast, $f_a = 3$
C - hohe Überlast, $f_a = 10$

$$f_a = J_{ex} / J_m$$

- J_{ex} (kgm²) Massenträgheitsmoment der Last reduziert auf die Motorwelle
- J_m (kgm²) Massenträgheitsmoment des Motors
- Bei $f_a > 10$ bitte Kontakt mit dem technischen Büro aufnehmen

The service factor (f.s.) depends on the operating conditions the gearbox is used for. Following parameters need to be considered to select the right service factor.

- type of load of the operating machine A - B - C
- length of daily operating time: hours/day
- start-up frequency: starts/hour (*)

TYPE OF LOAD: A - uniform, $f_a = 0,3$
B - moderate shocks, $f_a = 3$
C - heavy shocks, $f_a = 10$

$$f_a = J_{ex} / J_m$$

- J_{ex} (kgm²) moment of the external inertia reduced at the drive shaft
- If $f_a > 10$ please contact the technical office

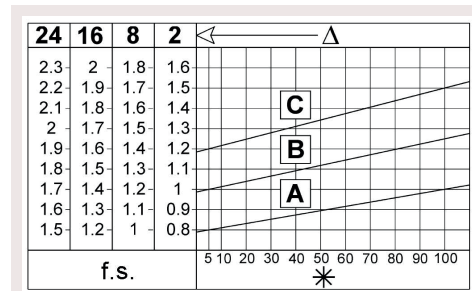

1.2 Einbau – *Installation*

Für den Einbau eines Getriebes sind folgende Anweisungen zu berücksichtigen:

- Die Befestigung an der Maschine muss absolut stabil sein, um jegliche Vibration zu vermeiden.
- Vor der Montage des Getriebes an der Maschine ist die Abtriebswelle des Getriebes auf die richtige Drehrichtung zu prüfen.
- Nach besonders langer Einlagerung (4-6 Monate) ist zu überprüfen, ob die Wellendichtringe vom Schmiermittel des Getriebes vollständig benetzt wurden. Andernfalls ist ein Austausch anzuraten, da die Dichtlippe auf der Welle festkleben kann und die zum einwandfreien Betrieb erforderliche Elastizität nicht mehr vorhanden ist.
- Bei Pendelbefestigung eines Getriebes mit Abtriebshohlwelle ist die Drehmomentstütze zu verwenden. Als Alternative muss kundenseitig eine geeignete Drehmomentabstützung eingesetzt werden, wobei hier weder axiale noch radiale Kippmomentbelastungen auf die Lager erzeugt werden dürfen.
- Wenn möglich sollte das Getriebe vor Sonnenbestrahlung und anderen Witterungseinflüssen geschützt werden.
- Die Motorkühlung muß durch eine gute Belüftung auf der Seite des Lüfters gewährleistet werden.
- Bei Umgebungstemperaturen $< -5^{\circ}\text{C}$ und $> +40^{\circ}\text{C}$ setzen Sie sich bitte mit dem technischen Büro in Verbindung.
- Zur Montage der unterschiedlichen Anbauteile (Riemenscheiben, Zahnräder, Kupplungen, Wellen, usw.) auf den Hohl- und Vollwellen sind die vorgesehenen Gewindebohrungen oder Aufziehvorrüchtungen zu verwenden. Diese gewährleisten eine einwandfreie Montage, ohne die Lager oder die Außenteile des Getriebes zu beschädigen. Die in Berührung kommenden Passungen und Oberflächen der Wellen sind zu fetten/ölen, um ein Festfressen durch Passungsrost zu vermeiden.
- Bei Lackierungen ist darauf zu achten, dass alle Gummiteile und gegebenenfalls die Gewindebohrungen für die Entlüftungsventile nicht überlackiert werden.
- Der Antrieb ist stufenweise in Betrieb zu nehmen, wobei zunächst mit Teillast angefahren werden sollte.
- Sind unter dem Antrieb Geräteteile oder Materialien angeordnet, die durch geringe Mengen austretenden Öls beschädigt werden könnten, so ist eine geeignete Schutzvorrichtung vorzusehen.

To install the gearbox unit it is necessary to note the following advices:

- The mounting on the machine must be stable to avoid any vibration.
- Check the correct direction of rotation of the reduction unit output shaft before fitting the unit to the machine.
- In the case of particularly length of periods of storage (4-6 months) if the oil seal is not immersed in the lubricant inside the unit, it is recommended to change it since the rubber could stick to the shaft or even has lost the elasticity it needs to function properly.
- For a shaft mounting, for reduction units with hollow output shafts, use the torque arms. If it is not possible, make sure that the constraint is axially free and with such as play as to ensure free movement to the reduction unit.
- Whenever possible, protect the reduction unit against solar radiation and bad weather.
- In the case of ambient temperatures $< -5^{\circ}\text{C}$ and $> +40^{\circ}\text{C}$ contact the technical office.
- holes or other systems that anyhow ensure correct operation without risking damage to the bearings or external parts of the units.
- Painting must definitely not go over rubber parts and the holes on the breather plugs, if there are any.
- Starting must take place gradually, without immediately applying the maximum load.
- If there are parts, objects or materials under the motor drive that can be damaged by even limited spillage of oil, special protection should be fitted.



1.3 Schmierung – Lubrication

Bei in der Übersicht nicht vorgesehenen Umgebungstemperaturen setzen Sie sich bitte mit dem technischen Büro in Verbindung.

Bei Temperaturen unter -30°C oder über +60°C werden Dichtringe aus besonderen Elastomeren benötigt.

Bei Betrieb unter 0°C ist Folgendes zu berücksichtigen:

- Die Motoren müssen für den Betrieb mit den vorgesehenen niedrigen Temperaturen geeignet sein.
- Die Leistung des Motors muss so ausgelegt werden, dass die höheren benötigten Anlaufdrehmomente aufgebracht werden können.
- Bei Getrieben aus Guss sind Stoßbelastungen zu beachten, weil der Guss bei Temperaturen unter -15°C verspröden könnte.
- Bei Betriebsbeginn könnten Schmierungsprobleme infolge der hohen Ölviskosität auftreten. Daher ist es sinnvoll, für einige Minuten einen Leerlauf auszuführen.

Die Getriebe der Größe 025-090 sind lebensdauer geschmiert, komplett geschlossen und benötigen daher keine Wartung.

Die Getriebegrößen 110-150 werden entsprechend der Einbaulage mit Öl befüllt; ohne Angabe der Einbaulage wird das Getriebe für B3 befüllt. Für die Einbaulagen V5 und V6 halten Sie bitte Rücksprache mit dem technischen Büro.

In cases of ambient temperatures not envisaged in the table, call the technical office.

In the case of temperatures under -30°C and over +60°C it is necessary to use oil seals with special properties.

For operating ranges with temperatures under 0°C it is necessary to consider the following:

- *The motors need to be suitable for operating at the envisaged ambient temperature.*
- *The power of the electric motor needs to be adequate for exceeding the higher starting torques required.*
- *In case of reduction units with a cast-iron case, pay attention to impact loads since cast iron may have problems of fragility at temperatures under -15°C*
- *During the early stages of service, problems of lubrication may arise due to the high level of viscosity taken on by the oil and so it is wise to have a few minutes under rotation under no load.*

Units 025-090 are supplied with "long-life" lubrication, they are completely closed and maintenance is not necessary.

The sizes 110-150 will be filled with oil according to the mounting position. For standard mounting the gearbox will be filled for B3 mounting position. For the mounting positions V5 and V6 please call the technical office.

synthetisches Öl synthetic oil	T °C	ISO VG...	AGIP	AGIP	SHELL	ESSO	MOBIL	CASTROL
	(-25) +(60)	ISO VG320	Telium VSF320	BLASIA S320	Tivela Oil SC320	SS220	Glygoyle 30	Alphasyn PG320

KG	025	030	040	050	063	075	090	110	130	150
B3	0,02	0,04	0,08	0,15	0,30	0,55	1	3	4,5	7,0
B8	0,02	0,04	0,08	0,15	0,30	0,55	1	2,2	3,3	5,1
B6/B7	0,015	0,025	0,05	0,10	0,20	0,35	0,7	2,2	3,3	5,1
V5	0,02	0,04	0,08	0,15	0,30	0,55	1	3	4,5	7,0
V6	0,02	0,04	0,08	0,15	0,30	0,55	1	2,2	3,3	5,1

Klemmkastenlage – Position of terminal box – unabhängig der Einbaulage

Bei Auftragserteilung ist die Klemmkastenlage gemäß Schema anzugeben, ohne Angabe wird standardmäßig "B" geliefert.

When ordering, specify the position of the terminal box as shown in the diagram; otherwise it will be supplied in position "B".

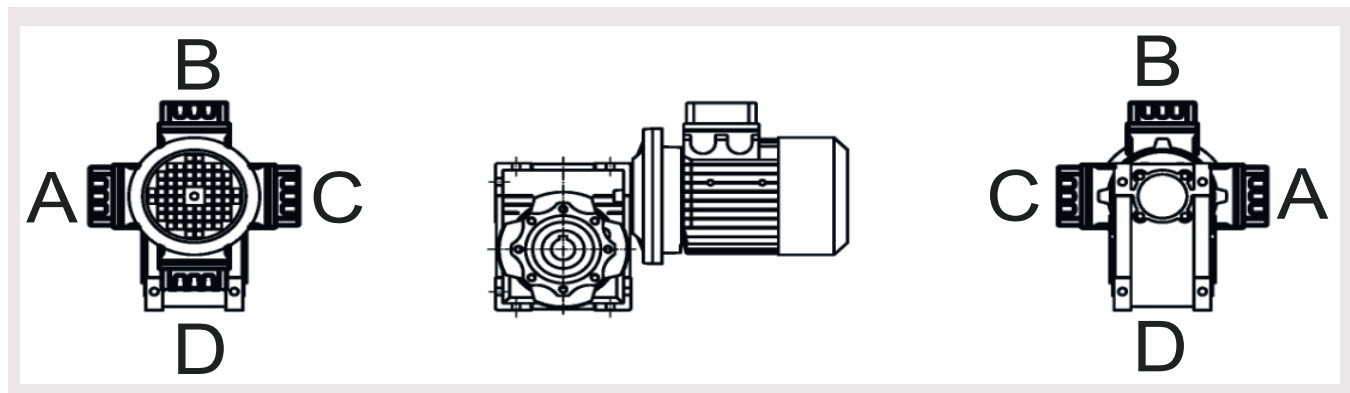

1.4 Wirkungsgrad–Selbsthemmung – Efficiency–irreversibility

Der Wirkungsgrad ist entscheidend für die Auslegung einer Anwendung und wird von den Verzahnungsdaten beeinflusst. In der Übersicht der Verzahnungsdaten finden Sie Werte des dynamischen ($n_1=1400$) und des statischen Wirkungsgrades. Es wird darauf hingewiesen, dass diese Tabellenwerte erst nach der Einlaufzeit gültig sind. Bei einem Getriebe mit dynamischer Selbsthemmung tritt sofortiger Stillstand der Abtriebswelle ein, wenn die Schneckenwelle nicht mehr angetrieben wird. Die theoretische Voraussetzung für dynamische Selbsthemmung ist ein dynamischer Wirkungsgrad $\eta_d < 0,5$. Bei statischer Selbsthemmung ist ein Anlauf aus dem Stillstand bei treibender Abtriebswelle nicht möglich. Statische Selbsthemmung liegt bei einem statischen Wirkungsgrad $\eta_s < 0,5$ vor. In der Übersicht sind die Angaben zur Selbsthemmung nur als Richtwerte wiedergegeben. Die Bedingungen können durch Vibrationen oder Stöße beeinträchtigt werden. Bei der Prüfung der Selbsthemmung von Doppelschneckengetriebe ist zu beachten, dass sich der Gesamtwirkungsgrad aus dem Produkt der beiden einzelnen Wirkungsgrade ergibt, d.h. $\eta_g = \eta_1 \times \eta_2$.

Efficiency is a parameter which has a major influence on the sizing of certain applications, and basically depends on gear pair design elements. The mesh data table shows dynamic efficiency ($n_1=1400$) and static efficiency values. These values are only achieved after the unit has been run in. Dynamic irreversibility is achieved when the output shaft stops instantly when drive is no longer transmitted through the worm shaft. This condition requires a dynamic efficiency of $\eta_d < 0,5$. Static irreversibility is achieved, when, with the gear reducer at a standstill, the application of a load to the output shaft does not set in motion $\eta_s < 0,5$. The table shows approximate irreversibility classes. Vibrations and shocks can affect a gear reducer η_s irreversibility. For the irreversibility conditions of a combiend geared unit one must consider that the efficiency of the group is given by the product of the efficiencies of each single reducer; i.e. $\eta_g = \eta_1 \times \eta_2$.

η_d	DYNAMISCHE SELBSTHEMMUNG	DYNAMIC IRREVERSIBILITY
> 0,6	keine Selbsthemmung	dynamic reversibility
0,5 ÷ 0,6	leicht dynamisch reversierbar	low dynamic reversibility
0,4 ÷ 0,5	mittlere dynamische Selbsthemmung	low dynamic irreversibility
< 0,4	dynamische Selbsthemmung	dynamic irreversibility

η_s	STATISCHE SELBSTHEMMUNG	STATIC IRREVERSIBILITY
> 0,55	keine Selbsthemmung	static reversibility
0,5 ÷ 0,55	mittlere statische Selbsthemmung	low static reversibility
< 0,5	statische Selbsthemmung	static irreversibility

Größe Size K-MG	Drehmoment Wirkungsgrad	Untersetzung/ratio i											
		5	7,5	10	15	20	25	30	40	50	60	80	100
025	Mn	*	11	12	12	12	-	14	13	11	9	-	-
	η_d (1400)	*	0,85	0,83	0,8	0,75	-	0,67	0,62	0,54	0,45	-	-
	η_s	*	0,72	0,69	0,64	0,56	-	0,45	0,38	0,29	0,20	-	-
030	Mn	18	18	19	17	18	21	19	17	18	17	13	-
	η_d (1400)	0,87	0,87	0,83	0,77	0,73	0,68	0,65	0,59	0,56	0,51	0,38	-
	η_s	0,74	0,76	0,69	0,59	0,53	0,46	0,42	0,35	0,31	0,26	0,14	-
040	Mn	33	40	42	41	39	37	43	41	38	34	34	31
	η_d (1400)	0,89	0,89	0,86	0,82	0,78	0,75	0,71	0,65	0,62	0,58	0,52	0,47
	η_s	0,74	0,79	0,74	0,67	0,61	0,56	0,50	0,42	0,38	0,34	0,27	0,22
050	Mn	62	70	70	76	71	70	79	74	72	72	66	55
	η_d (1400)	0,89	0,89	0,86	0,82	0,79	0,75	0,71	0,67	0,63	0,59	0,54	0,49
	η_s	0,74	0,79	0,74	0,67	0,62	0,56	0,50	0,45	0,40	0,35	0,29	0,24
063	Mn	-	123	143	140	133	130	160	143	135	130	125	112
	η_d (1400)	-	0,87	0,87	0,83	0,81	0,77	0,71	0,7	0,66	0,47	0,56	0,50
	η_s	-	0,76	0,76	0,69	0,66	0,59	0,50	0,49	0,44	0,22	0,31	0,25
075	Mn	-	181	191	209	207	200	230	221	219	200	198	180
	η_d (1400)	-	0,87	0,88	0,84	0,82	0,79	0,76	0,72	0,69	0,65	0,60	0,48
	η_s	-	0,76	0,77	0,71	0,67	0,62	0,58	0,52	0,48	0,42	0,36	0,23
090	Mn	-	283	319	367	377	338	425	367	369	342	283	270
	η_d (1400)	-	0,90	0,89	0,86	0,84	0,82	0,77	0,75	0,72	0,69	0,63	0,53
	η_s	-	0,81	0,79	0,74	0,71	0,67	0,59	0,56	0,52	0,48	0,40	0,28
110	Mn	-	557	601	669	650	695	726	694	675	663	492	460
	η_d (1400)	-	0,90	0,89	0,86	0,86	0,84	0,79	0,77	0,73	0,72	0,68	0,61
	η_s	-	0,81	0,79	0,74	0,74	0,71	0,62	0,59	0,53	0,52	0,46	0,37
130	Mn	-	770	839	901	880	967	990	1114	1005	990	883	717
	η_d (1400)	-	0,91	0,89	0,87	0,86	0,84	0,80	0,79	0,76	0,73	0,67	0,64
	η_s	-	0,83	0,79	0,76	0,74	0,71	0,64	0,62	0,58	0,53	0,45	0,41
150	Mn	-	5,5	6,155	5,5	6,155	5	4,193	6,155	5	4,193	3,17	2,55
	η_d (1400)	-	0,91	0,9	0,88	0,86	0,84	0,83	0,78	0,76	0,73	0,68	0,64
	η_s	-	0,73	0,71	0,66	0,6	0,57	0,54	0,45	0,42	0,39	0,33	0,29

Alle Angaben ohne Gewähr,

*auf Anfrage

Mn Nennmoment/rated torque

η_d (1400) Dynamischer Wirkungsgrad bei $n_1=1400$ min-1/dynamic efficiency at $n_1=1400$ min-1

η_s Statischer Wirkungsgrad/static efficiency



1.5 Schneckengetriebe K-G/K-MG – Worm gearboxes K-G/K-MG

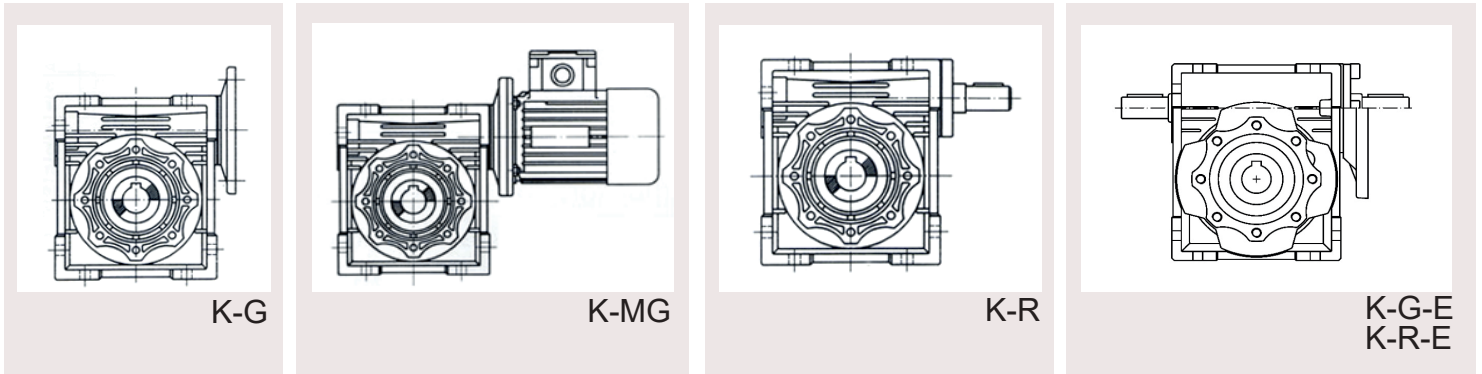

Größe/Size
KG 025
KG 030
KG 040
KG 050
KG 063
KG 075
KG 090
KG 110
KG 130
KG 150

Montage/Mounting + Optionen/Options
Flanschgröße FA-FE/Flange size FA-FE
Drehmomentstütze BR/Torque arm BR
Zweite Eintriebswelle ZW/Second input shaft ZW
Abtriebswellen S/D/Output shafts S/D
Schutzkappen SK/Protective caps SK

Abmaße und technische Daten siehe Seiten 12 und 13

1.6 Stirnradvorstufen – Helical prestages

Größe/Size
KMGV
045-150

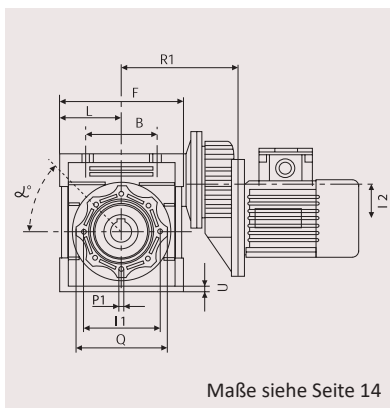

Doppelschneckengetriebe – Double worm gearboxes

Größe/Size
KMGD
030/40-063/150

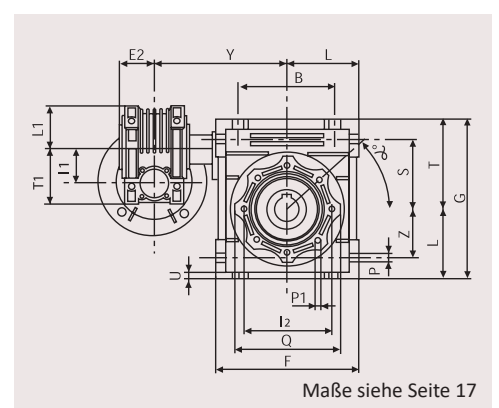

1.7 Einbaulagen – Mounting positions

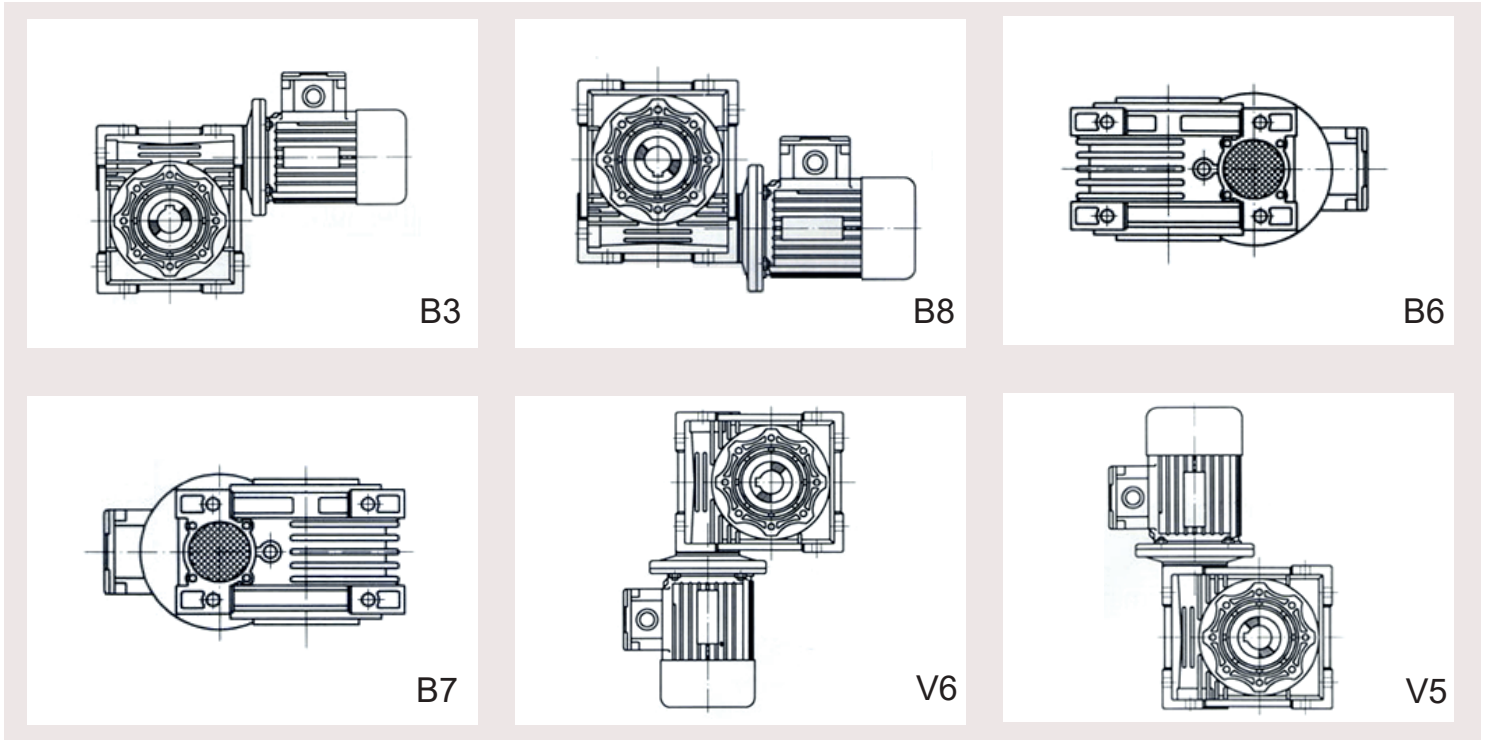

1.8 Typenschlüssel – Designation

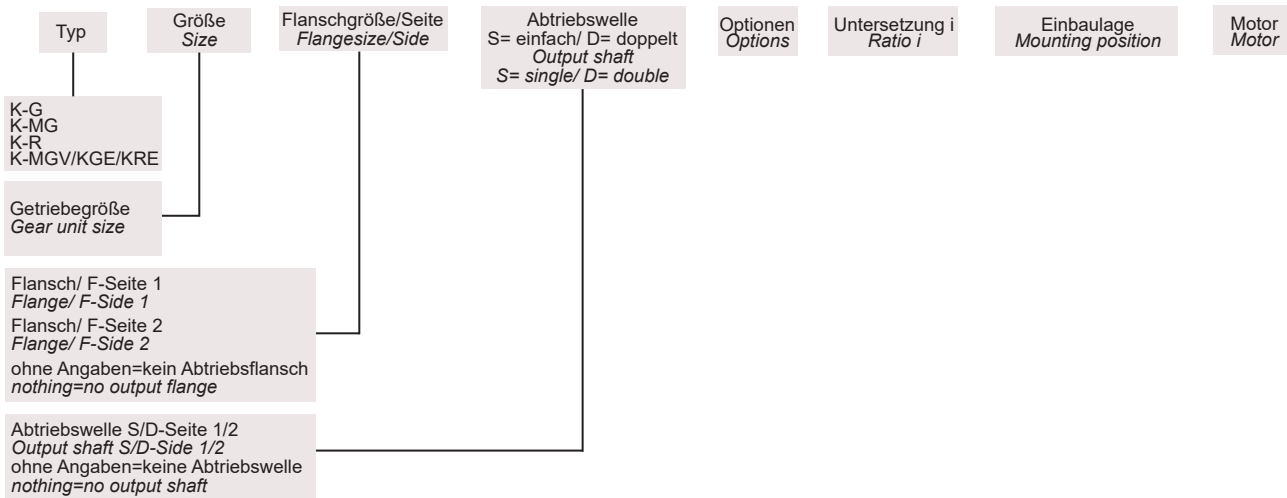

1.9 Ausführungen – Versions

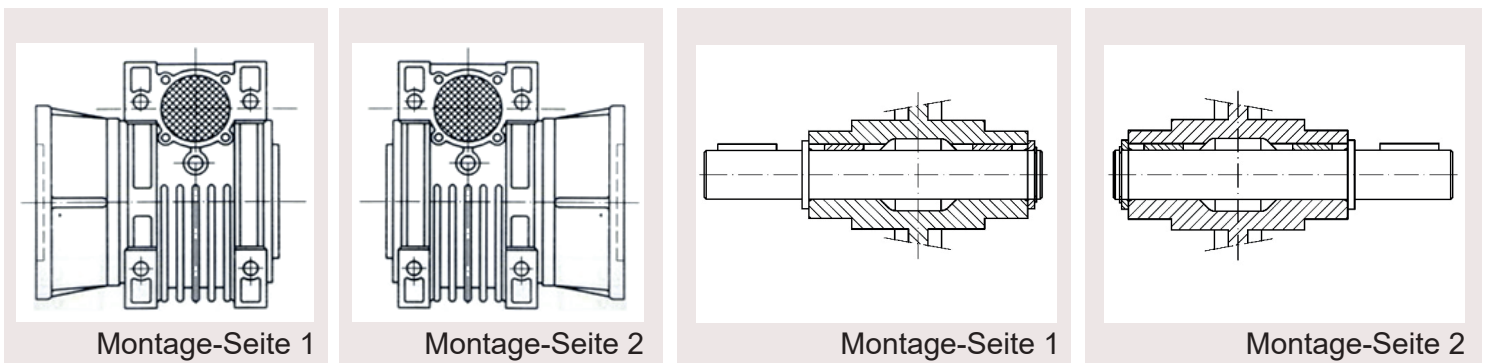

2.0 Auswahltabellen – Selection charts

Größe Size	n2 [1/min]	i	P [kW]	M2 [Nm]	fb	P1 max	M2 max	56 B5	63 B5	71 B5	80 B5	90 B5	100/112 B5	132 B5	56 B14	63 B14	71 B14	80 B14	90 B14	Efficiency η	Kg
K - M G 0 2 5	187	7,5	0,06	2	4,2	0,25	10													0,8	1
			0,09	4	2,8	0,25	10														
	140	10	0,06	3	3,5	0,21	11													0,8	
			0,09	5	2,3	0,21	11													0,8	
	93	15	0,06	4	2,2	0,13	10													0,73	
			0,09	7	1,4	0,13	10													0,73	
	70	20	0,06	6	1,8	0,11	11													0,7	
			0,09	9	1,2	0,11	11													0,7	
	56	25	0,06	7	1,8	0,11	11													0,7	
			0,09	10	1,2	0,11	11													0,7	
	47	30	0,06	8	1,7	0,1	13													0,62	
			0,09	11	1,1	0,1	13													0,62	
	35	40	0,06	9	1,3	0,08	12													0,57	
	28	50	0,06	11	0,8	0,05	9													0,54	
23	60	0,06	12	0,7	0,04	8													0,5		
K - M G 0 3 0	280	5	0,12	4	5,1	0,61	18													0,87	1,2
			0,18	5	3,4	0,61	18													0,87	
	187	7,5	0,12	5	3,5	0,42	17													0,8	
			0,18	7	2,3	0,42	17													0,8	
	140	10	0,12	6	2,3	0,28	15													0,78	
			0,18	10	1,6	0,28	15													0,78	
	93	15	0,12	9	2	0,24	18													0,73	
			0,18	13	1,3	0,24	18													0,73	
	70	20	0,12	11	1,7	0,2	19													0,7	
			0,18	17	1,1	0,2	19													0,7	
	56	25	0,12	13	1,3	0,16	18													0,65	
			0,18	20	0,9	0,16	18													0,65	
	47	30	0,12	15	1,3	0,16	20													0,62	
			0,18	19	1,1	0,13	20													0,62	
	35	40	0,12	19	1,1	0,13	20													0,57	
	28	50	0,06	11	1,7	0,1	18													0,54	
	23	60	0,09	19	1	0,09	19													0,5	
	18	80	0,06	16	1	0,06	16													0,56	
K - M G 0 4 0	280	5	0,25	8	4,4	1,1	33													0,89	2,3
			0,37	10	3	1,1	33													0,89	
			0,55	16	2	1,1	33														
	187	7,5	0,25	10	3	0,76	31													0,8	
			0,37	15	2,1	0,76	31													0,8	
	140	10	0,25	13	2,8	0,71	38													0,79	
			0,37	20	1,9	0,71	38													0,79	
	93	15	0,25	21	1,6	0,39	32													0,8	
			0,37	30	1,1	0,39	32													0,8	
	70	20	0,25	24	1,6	0,41	39													0,69	
			0,37	35	1,1	0,41	39													0,69	
	56	25	0,25	28	1,6	0,4	44													0,65	
			0,12	16	2,6	0,31	41													0,65	
	47	30	0,18	24	1,7	0,31	41													0,65	
			0,25	33	1,2	0,31	41													0,65	
	35	40	0,12	21	1,9	0,23	40													0,63	
			0,18	31	1,3	0,23	40													0,63	
	28	50	0,09	18	2	0,18	36													0,59	
			0,12	24	1,5	0,18	36													0,59	
	23	60	0,18	36	1	0,18	36													0,59	
0,09			19	1,6	0,14	29													0,56		
18	80	0,12	25	1,2	0,14	29													0,56		
		0,09	24	1,2	0,11	29													0,54		
14	100	0,12	32	0,9	0,11	29												0,54			
14	100	0,09	31	0,9	0,08	27													0,49		
K - M G 0 5 0	280	5	0,75	23	2,6	1,9	62													0,89	3,5
			0,55	23	2,5	1,4	59													0,82	
	187	7,5	0,75	31	1,9	1,4	59													0,82	
			0,37	20	3	1,1	60													0,8	
	140	10	0,55	30	2	1,1	60													0,8	
			0,75	41	1,5	1,1	60													0,8	
	93	15	0,37	30	1,7	0,64	52													0,79	
			0,55	45	1,2	0,64	52													0,79	
	70	20	0,75	61	0,9	0,64	52													0,79	
			0,25	26	2,6	0,64	65													0,75	
	56	25	0,37	38	1,7	0,64	65													0,75	
			0,55	56	1,2	0,64	65													0,75	
	47	30	0,25	29	2,1	0,52	61													0,69	
			0,37	44	1,4	0,52	61													0,69	
	35	40	0,55	65	0,9	0,52	61													0,69	
			0,25	35	2,1	0,52	73													0,69	
	28	50	0,37	52	1,4	0,52	73													0,69	
			0,55	77	0,9	0,52	73													0,69	
	23	60	0,18	33	2,2	0,4	74													0,68	
			0,25	46	1,6	0,4	74													0,68	
	18	80	0,37	69	1,1	0,4	74													0,68	
			0,18	39	1,7	0,3	64													0,63	
	14	100	0,25	54	1,2	0,3	64													0,63	
			0,12	25	2,1	0,25	52													0,58	
93	15	0,18	37	1,4	0,25	52													0,58		
		0,25	52	1	0,25	52													0,58		
70	20	0,12	32	1,5	0,18	48													0,54		
		0,18	48	1	0,18	48													0,54		
56	25	0,12	41	1,2	0,14	48												0,5			



Größe Size	n2 [1/min]	i	P [kW]	M2 [Nm]	fb	P1 max	M2 max	56 B5	63 B5	71 B5	80 B5	90 B5	100/112 B5	132 B5	56 B14	63 B14	71 B14	80 B14	90 B14	Efficiency η	Kg	
K - M G 0 6 3	187	7,5	1,1	47	2,7	3	127													0,83	6,2	
			1,5	64	2	3	127															0,83
	140	10	1,1	61	2,1	2,3	127															0,81
			1,5	83	1,5	2,3	127															0,81
	93	15	0,75	61	2,1	1,6	130															0,79
			1	89	1,5	1,6	130															0,79
			1,5	122	1,1	1,6	130															0,79
	70	20	0,55	59	2,9	1,6	170					24										0,78
			0,75	80	2,1	1,6	170															0,78
			1,1	117	1,5	1,6	170															0,78
	56	25	0,55	70	2	1,1	141					19										0,75
			0,75	96	1,5	1,1	141															0,75
	47	30	0,55	83	1,7	0,92	138															0,74
			0,75	113	1,2	0,92	138															0,74
	35	40	0,37	68	2,2	0,8	146															0,67
			0,55	101	1,5	0,8	146															0,67
			0,75	137	1,1	0,8	146															0,67
	28	50	0,25	55	2,4	0,6	133					14										0,65
			0,37	82	1,6	0,6	133															0,65
			0,55	122	1,1	0,6	133															0,65
	23	60	0,25	52	1,9	0,48	100															0,62
			0,37	77	1,3	0,48	100															0,62
	18	80	0,25	66	1,4	0,36	96															0,57
			0,37	98	1	0,36	96															0,57
14	100	0,25	85	1,2	0,31	106														0,52		

Größe Size	n2 [1/min]	i	P [kW]	M2 [Nm]	fb	P1 max	M2 max	71 B5	80 B5	90 B5	100/112 B5	132 B5	56 B14	63 B14	71 B14	80 B14	90 B14	110/112 B14	132 B14	Efficiency η	Kg
K - M G 0 7 5	187	7,5	2,2	93	1,8	3,9	165														0,83
			3	127	1,3	3,9	165														0,83
	140	10	1,5	83	2,1	3,2	177														0,81
			2,2	122	1,5	3,2	177														0,81
	93	15	1,1	89	2,2	2,4	195														0,79
			1,5	122	1,6	2,4	195														0,79
			2,2	178	1,1	2,4	195														0,79
	70	20	1,1	120	1,6	1,8	196														0,8
			1,5	164	1,2	1,8	196														0,8
			0,75	101	1,9	1,4	189														0,79
	56	25	1,1	148	1,3	1,4	189														0,79
			1,5	202	0,9	1,4	189														0,79
			0,75	117	2	1,47	224														0,75
	47	30	1,1	168	1,3	1,47	224														0,75
			1,5	229	1	1,47	224														0,75
	35	40	0,55	105	1,8	1	191														0,7
			0,75	143	1,3	1	191														0,7
			1,1	210	0,9	1	191														0,7
	28	50	0,55	124	1,6	0,9	203														0,66
			0,75	169	1,2	0,9	203														0,66
	23	60	0,37	77	1,9	0,7	145														0,65
			0,55	114	1,3	0,7	145														0,65
	18	80	0,37	98	1,6	0,6	159														0,6
			0,55	146	1,1	0,6	159														0,6
14	100	0,37	126	1,4	0,5	171														0,55	

Größe Size	n2 [1/min]	i	P [kW]	M2 [Nm]	fb	P1 max	M2 max	71 B5	80 B5	90 B5	100/112 B5	132 B5	56 B14	63 B14	71 B14	80 B14	90 B14	110/112 B14	132 B14	Efficiency η	Kg
K - M G 0 9 0	187	7,5	2,2	99	2,6	5,8	261														0,88
			3	135	1,9	5,8	261														0,88
	140	10	2,2	120	2,4	5,2	284														0,8
			3	164	1,7	5,2	284														0,8
	93	15	4	218	1,3	5,2	284														0,8
			2,2	181	2	4,3	353														0,8
			3	246	1,4	4,3	353														0,8
	70	20	4	329	1,1	4,3	353														0,8
			1,5	164	1,9	2,8	306														0,8
			2,2	240	1,3	2,8	306														0,8
	56	25	3	327	0,9	2,8	306														0,8
			1,5	200	1,6	2,4	319														0,78
			2,2	293	1,1	2,4	319														0,78
	47	30	1,5	232	1,8	2,7	417														0,76
			2,2	340	1,2	2,7	417														0,76
	35	40	1,1	213	1,5	1,7	329														0,71
			1,5	291	1,1	1,7	329														0,71
	28	50	0,75	169	1,9	1,4	315														0,66
			1,1	248	1,3	1,4	315														0,66
	23	60	0,75	156	1,6	1,2	249														0,67
			1,1	228	1,1	1,2	249														0,67
	18	80	0,55	146	1,5	0,82	218														0,62
			0,75	199	1,1	0,82	218														0,62
	14	100	0,55	188	0,9	0,5	171														0,59



Größe Size	n2 [1/min]	i	P [kW]	M2 [Nm]	fb	P1 max	M2 max	71 B5	80 B5	90 B5	100/112 B5	132 B5	56 B14	63 B14	71 B14	80 B14	90 B14	110/112 B14	132 B14	Efficiency η	Kg																																																																																																																																										
K - M G 1 1 0	187	7,5	5,5	247	2	10,9	490														0,88	35																																																																																																																																									
			7,5	337	1,5	10,9	490														0,88																																																																																																																																										
			4	235	2,1	8,5	499														0,86																																																																																																																																										
	140	10	5,5	323	1,5	8,5	499																														0,86																																																																																																																										
			7,5	440	1,1	8,5	499																														0,86																																																																																																																										
			3	253	1,9	5,7	480																														0,82																																																																																																																										
	93	15	4	337	1,4	5,7	480																																														0,82																																																																																																										
			5,5	463	1	5,7	480																																														0,82																																																																																																										
			2,2	246	2,1	4,6	515																																														0,82																																																																																																										
	70	20	3	336	1,5	4,6	515																																																															0,82																																																																																									
			4	447	1,2	4,6	515																																																															0,82																																																																																									
			2,2	300	1,8	3,9	532																																																															0,8																																																																																									
	56	25	3	409	1,3	3,9	532																																																																																	0,8																																																																							
			4	546	1	3,9	532																																																																																	0,8																																																																							
			2,2	340	1,8	4	618																																																																																	0,76																																																																							
	47	30	3	463	1,3	4	618																																																																																																				0,76																																																				
			4	618	1	4	618																																																																																																				0,76																																																				
			1,5	307	2	3	614																																																																																																				0,75																																																				
	35	40	2,2	450	1,4	3	614																																																																																																																							0,75																																	
			3	614	1	3	614																																																																																																																							0,75																																	
			1,1	263	2,2	2,4	573																																																																																																																							0,7																																	
	28	50	1,5	358	1,6	2,4	573																																																																																																																																										0,7														
			2,2	525	1,1	2,4	573																																																																																																																																										0,7														
			1,1	228	1,8	2	415																																																																																																																																										0,69														
23	60	1,5	311	1,3	2	415																																																																																																																																															0,69										
		0,55	146	2,4	1,3	345																																																																																																																																															0,65										
		0,75	199	1,7	1,3	345																																																																																																																																															0,65										
18	80	1,1	292	1,2	1,3	345																																																																																																																																																			0,65						
		0,75	256	1,5	1,1	375																																																																																																																																																			0,6						
		1,1	375	1	1,1	375																																																																																																																																																			0,6						
14	100	5,5	247	3	16,5	742																																																																																																																																																						0,88			
		7,5	337	2,2	16,5	742																																																																																																																																																						0,88			
		5,5	323	2,5	13,8	810																																																																																																																																																						0,86			
140	10	7,5	440	1,8	13,8	810																																																																																																																																																								0,86	
		5,5	480	1,8	10	873																																																																																																																																																								0,85	
		7,5	655	1,3	10	873																																																																																																																																																								0,85	
93	15	5,5	638	1,3	7,3	847																																																																																																																																																									0,85
		7,5	870	1	7,3	847																																																																																																																																																									0,85
		4	566	1,6	6,4	906																																																																																																																																																									0,83
70	20	5,5	778	1,2	6,4	906																																																																																																																																																									0,83
		4	654	1,5	6	975																																																																																																																																																									0,8
		5,5	894	1,1	6	975																																																																																																																																																									0,8
56	25	2,2	462	2,4	5,2	1093																																																																																																																																																									0,77
		3	630	1,7	5,2	1093																																																																																																																																																									0,77
		4	840	1,3	5,2	1093																																																																																																																																																									0,77
47	30	2,2	555	1,7	3,8	959																																																																																																																																																									0,74
		3	757	1,3	3,8	959																																																																																																																																																									0,74
		4	1010	1	3,8	959																																																																																																																																																									0,74
35	40	2,2	457	1,5	3,2	664																																																																																																																																																									0,71
		3	623	1,1	3,2	664																																																																																																																																																									0,71
		1,1	292	2,2	2,4	637																																																																																																																																																									0,68
28	50	1,5	398	1,6	2,4	637																																																																																																																																																									0,68
		2,2	584	1,1	2,4	637																																																																																																																																																									0,68
		1,1	375	1,5	1,6	546																																																																																																																																																									0,64
23	60	1,5	512	1,1	1,6	546																																																																																																																																																									0,64
		5,5	250	4,3	24	1088																																																																																																																																																									0,88
		7,5	340	3,2	24	1088																																																																																																																																																									0,88
187	7,5	11	500	2,2	24	1088																																																																																																																																																									0,88
		15	680	1,6	24	1088																																																																																																																																																									0,88
		5,5	330	3,2	18	1086																																																																																																																																																									0,86
140	10	7,5	450	2,4	18	1086																																																																																																																																																									0,86
		11	665	1,6	18	1086																																																																																																																																																									0,86
		15	905	1,2	18	1086																																																																																																																																																									0,86
93	15	5,5	480	2,4	13,5	1180																																																																																																																																																									0,82
		7,5	655	1,8	13,5	1180																																																																																																																																																									0,82
		11	960	1,2	13,5	1180																																																																																																																																																									0,82
70	20	15	1310	0,9	13,5	1180																																																																																																																																																									0,82
		4	460	2,7	11	1270																																																																																																																																																									0,82
		5,5	635	2	11	1270																																																																																																																																																									0,82
56	25	7,5	870	1,5	11	1270																																																																																																																																																									0,82
		11	1270	1	11	1270																																																																																																																																																									0,8
		5,5	760	1,6	9	1220																																																																																																																																																									0,8
47	30	7,5	1040	1,2	9	1220																																																																																																																																																									0,8
		9	1270	1	9	1220																																																																																																																																																									0,8
		11	1520	0,8	9	1220																																																																																																																																																									0,8
35	40	4	660	1,5	6	990																																																																																																																																																									0,76
		5,5	910	1,1	6	990																																																																																																																																																									0,76
		7,5	1240	0,8	6	990																																																																																																																																																									0,76
28	50	4	830	1,6	6,4	1405																																																																																																																																																									0,75
		5,5	1150	1,2	6,4	1405																																																																																																																																																									0,75
		7,5	1560	0,9	6,4	1405																																																																																																																																																									0,75
23	60	3	766	1,5	5	1265																																																																																																																																																									0,7
		4	1020	1,2	5	1265																																																																																																																																																									0,7
		5,5	1405	0,9	5	1265																																																																																																																																																									0,7
18	80	2,2	645	2	4,5	1290																																																																																																																																																									0,69
		3	880	1,5	4,5	1290																																																																																																																																																									0,69
		4	1170	1,1	4,5	1290																																																																																																																																																									0,69
14	100	5,5	1610	0,8	4,5	1290																																																																																																																																																									0,69
		2,2	785	1,5	3,2	1145																																																																																																																																																									0,65
		3	1070	1,1	3,2	1145																																																																																																																																																									0,65
93	15	4	1430	0,8	3,2	1145																																																																																																																																																									0,65
		2,2	950	1,1	2,4	1040																																																																																																																																																									0,6
		3	1300	0,8	2,4	1040																																																																																																																																																									0,6



2.1 Abmessungen – Dimensions

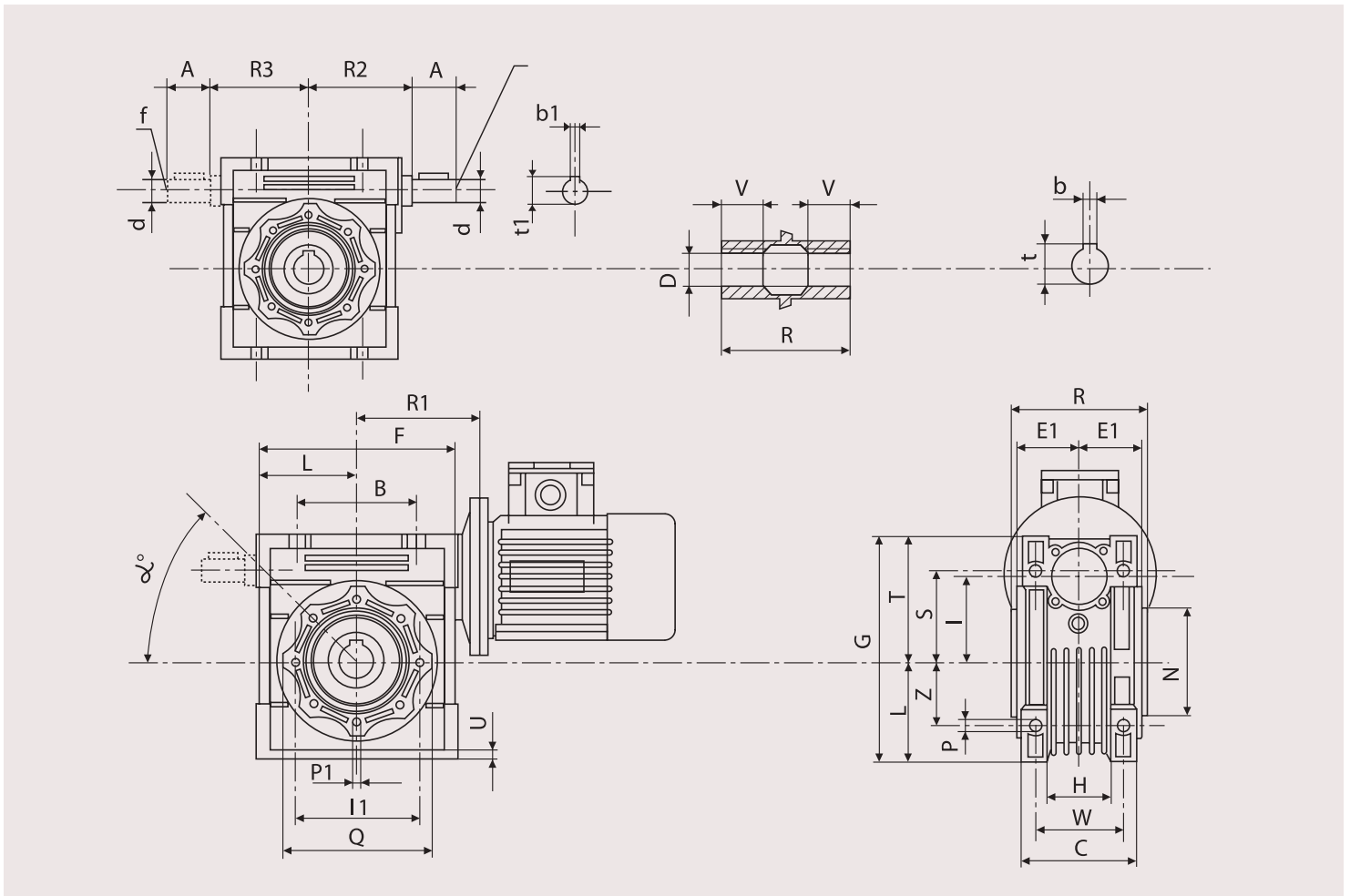

KG - KMG - KR - KGE - KRE 025 - 150

TYP	A	B	C	D(H7)	E1	F	G	H	I	I1	L	N(h8)	P	P1	Q	R	R1
025	..	45	42	11	22,5	71	83	22	25	55	35	45	6	M6x09	..	50	45
030	20	54	56	14	29	80	97	32	30	65	40	55	6,5	M6x11	75	63	55
040	23	70	71	18	36,5	100	121,5	43	40	75	50	60	6,5	M6x08	87	78	70
050	30	80	85	25	43,5	120	144	49	50	85	60	70	8,5	M8x10	100	92	80
063	40	100	103	25	53	144	174	67	63	95	72	80	8,5	M8x14	110	112	95
075	50	120	112	28	57	172	205	72	75	115	86	95	11	M8x14	140	120	112,5
090	50	140	130	35	67	208	238	74	90	130	103	110	13	M10x18	160	140	129,5
110	60	170	144	42	74	252,5	295	..	110	165	127,5	130	14	M10x18	200	155	160
130	80	200	155	45	81	292,5	335	..	130	215	147,5	180	16	M12x21	250	170	180
150	80	240	185	48	96	340	400	..	150	215	170	180	18	M12x21	250	200	210
TYP	R2	R3	S	T	U	V	W	Z	α	b	b1	d(j6)	f	t	t1	kg	Material
025	35,5	48	5	18	34	22,5	10°	4	12,8	..	1	Alu
030	51	45	44	57	5,5	21	44	27	0°	5	3	9	..	16,3	10,2	1,2	Alu
040	60	53	55	71,5	6,5	26	60	35	45°	6	4	11	..	20,8	12,5	2,3	Alu
050	74	64	64	84	7	30	70	40	45°	8	5	14	M6	28,3	16	3,5	Alu
063	90	75	80	102	8	36	85	50	45°	8	6	19	M6	28,3	21,5	6,2	Alu
075	105	90	93	119	10	40	90	60	45°	8	8	24	M8	31,3	27	85	Alu
090	125	108	102	135	11	45	100	70	45°	10	8	24	M8	38,3	27	12	Alu
110	142	135	125	167,5	14	50	115	85	45°	12	8	28	M10	45,3	31	22/35	Alu/GG
130	162	155	140	187,5	15	60	120	100	45°	14	8	30	M10	48,8	33	53	GG
150	195	175	180	230	18	72,5	145	120	45°	14	10	35	M12	53,8	38	78	GG

3.0 Montage und Optionen – Mounting and options

3.1 Abtriebsflansche FA-FE – Output flanges FA-FE

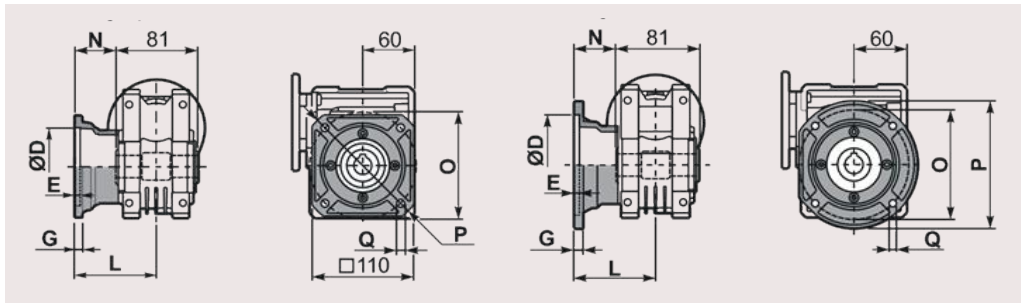

Typ	Maße	025	030	040	050	063	075	090	110	130	150
FA Quadrat	P	75	80	110	125	180	200	210	280	320	320
	□	70	70	95	110	142	170	200	260	290	290
	G	6	6	7	9	10	13	13	15	15	15
	O	70	68/72*	75/95*	85/110*	150/165*	165/185*	175/195*	230	255	255
	D	40	50	60	70	115	130	152	170	180	180
	Q	5,5	6,5	9	11	11	14	14	14	16	16
	E	2,5	4	4	5	6	6	6	6	6	6
L	45	54,5	67	90	82	111	111	131	140	155	
FB Quadrat	P			110	125	180	200	210	280		
	□			95	110	142	170	200	260		
	G			7	9	10	13	18	15		
	O			75/95*	85/110*	150/165*	130/145	215/230	230		
	D			60	70	115	110	180	170		
	Q			9	11	11	14	14	14		
	E			4	5	6	6	6	6		
L			97	120	112	90	122	180			
FC Rund	P			140	160	200	..	200			
	G			9	10	10	..	17			
	O			115	130	165	..	165/185*			
	D			95	110	130	..	130			
	Q			9,5	9,5	11	..	11			
	E			5	5	5	..	6			
	L			80	89	98	..	110			
FD Rund	P			120	140	200		210			
	G			12	14,5	10		13			
	O			100/110*	115/125*	165		175/195*			
	D			80	95	130		152			
	Q			9	11	11		14			
	E			5	5	5		6			
	L			58	72	107		151			
FE Rund	P					160					
	G					16,5					
	O					130/145*					
	D					110					
	Q					11					
	E					5					
	L					80,5					

Die Flansche mit den *- Maßen haben Langlöcher zur Befestigung

3.2 Zweite Eintriebswelle ZW – Second input shaft ZW

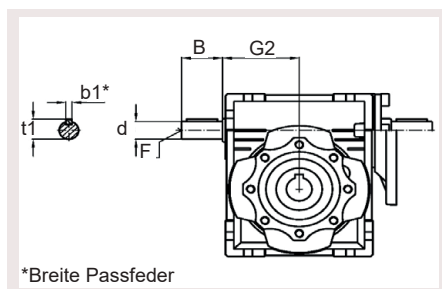

*Breite Passfeder

	G2	d(j6)	B	F	b1	t1
030	45	9	20	---	3	10.2
040	53	11	23	---	4	12.5
050	64	14	30	M6	5	16
063	75	19	40	M6	6	21.5
075	90	24	50	M8	8	27
090	108	24	50	M8	8	27
110	135	28	60	M10	8	31
130	155	30	80	M10	8	33
150	175	35	80	M12	10	38

3.3 Drehmomentstützen BR – Torque arms BR

Drehmomentstützen*					
	I	H	F	E	R
025	70	14	17.5	8	15
030	85	14	24	8	15
040	100	14	31.5	10	18
050	100	14	38.5	10	18
063	150	14	49	10	18
075	200	25	47.5	20	30
090	200	25	57.5	20	30
110	250	30	62	25	35
130	250	30	69	25	35
150	250	30	96	25	35

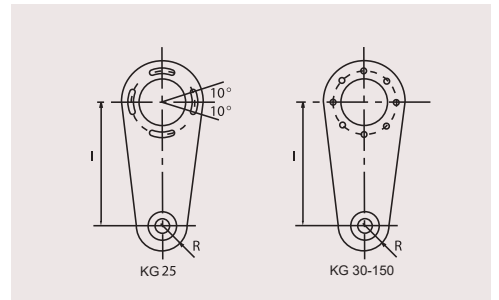
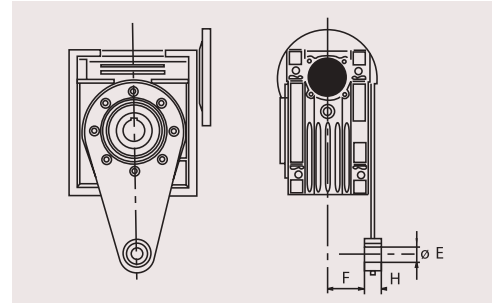

* Alle Drehmomentstützen mit Gummipuffer

3.4 Abtriebswellen einfach/doppelt S/D – Output shafts single/double S/D

Abtriebswellen einfach/doppelt									
	d	A	B	R	L	L1	d2	b	t1
025	11 h6	23	25.5	50	81	101	-	4	12.5
030	14 h6	30	32.5	63	102	128	M6	5	16
040	18 h6	40	43	78	128	164	M6	6	20.5
050	25 h6	50	53.5	92	153	199	M10	8	28
063	25 h6	50	53.5	112	173	219	M10	8	28
075	28 h6	60	63.5	120	192	247	M10	8	31
090	35 h6	80	84.5	140	234	309	M12	10	38
110	42 h6	80	84.5	155	249	324	M16	12	45
130	45 h6	80	85	170	265	340	M16	14	48.5
150	50 h6	82	87	210	297	374	M16	14	53,5

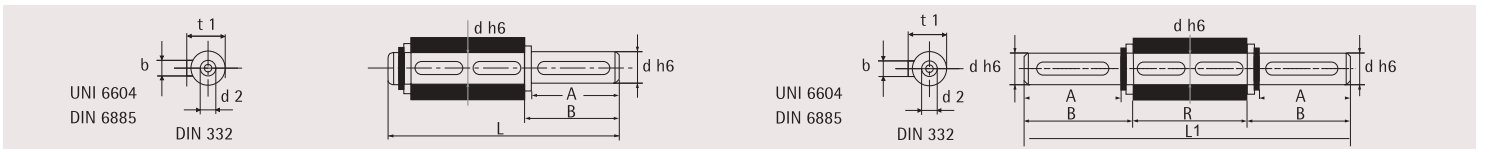

3.5 Schutzkappen SK – Protective caps SK

Schutzkappen	
Größe	C3
25	-
30	43
40	50
50	59
63	70
75	75
90	87
110	95
130	103
150	103

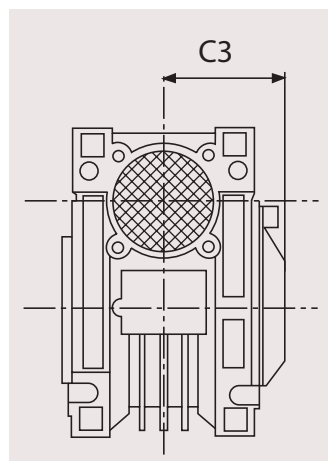

4.0 Stirradschneckengetriebe KMGV– Helical worm gearboxes KMGV

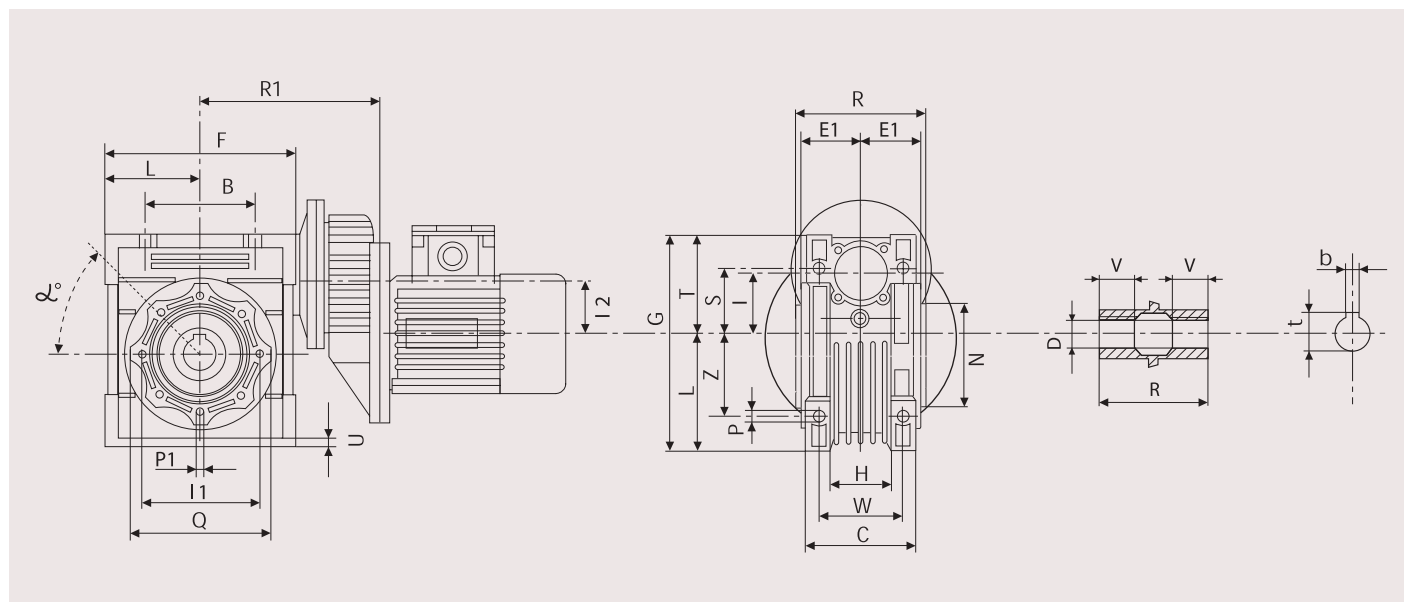

Bezeichnung KMGV

Typ	Größe	i	IEC/BG	Montage-Position
KV	63	3,00	63B5	Falls Lieferung mit KMG oder KMGE gekoppelt, bitte Position angeben. Wird die Vorstufe separat geliefert, ist die Universalposition vorgesehen.
KV	71	3,00	71B5	
KV	80	3,00	80B5	
KV	90	2,42	90B5	

KMGV	B	F	D(H7)	G	H	R1	R	L	I	I2	C	I1	N(h8)	E1	P	Q	S	T
63+040	70	100,0	18	121,5	43	123	78	50,0	40	40	71	75	60	36,5	6,5	87	55	71,5
63+050	80	120,0	25	144,0	49	133	92	60,0	50	40	85	85	70	43,5	8,5	100	65	84,0
71+050	80	120,0	25	144,0	49	143	92	60,0	50	50	85	85	70	43,5	8,5	100	64	84,0
63+063	100	144,0	25	174,0	67	148	112	72,0	63	40	103	95	80	53,0	8,5	110	80	102,0
71+063	100	144,0	25	174,0	67	158	112	72,0	63	50	103	95	80	53,0	8,5	110	80	102,0
71+075	120	172,0	28	205,0	72	176	120	86,0	75	50	112	115	95	57,0	11,0	140	93	119,0
80+075	120	172,0	28	205,0	72	186	120	86,0	75	63	112	115	95	57,0	11,0	140	93	119,0
71+090	140	208,0	35	238,0	74	193	140	103,0	90	50	130	130	110	67,0	13,0	160	102	135,0
80+090	140	208,0	35	238,0	74	193	140	103,0	90	63	130	130	110	67,0	13,0	160	102	135,0
80(90)+110	170	252,5	42	295,0	–	233	155	127,5	110	63	144	165	130	74,0	14,0	200	125	167,5
80(90)+130	200	292,5	45	335,0	–	253	170	147,5	130	63	155	215	180	81,0	16,0	250	140	187,5

KMGV	S	T	U	V	Z	WP1	α°	b	Gewicht in kg ohne Motor
63+040	6,5	26	35	60	M66x8n.4	45°	6	20,8	3,9
63+050	7,0	30	40	70	M8x10n.4	45°	8	28,3	5,2
71+050	7,0	30	40	70	M8x10n.4	45°	8	28,3	5,8
63+063	8,0	36	50	85	M8x14n.8	45°	8	28,3	7,9
71+063	8,0	36	50	85	M8x14n.8	45°	8	28,3	8,5
71+075	10,0	40	60	90	M8x14n.8	45°	8	31,3	11,0
80+075	10,0	40	60	90	M8x14n.8	45°	8	31,3	12,6
71+090	11,0	45	70	100	M10x18n.8	45°	10	38,3	14,3
80+090	11,0	45	70	100	M10x18n.8	45°	10	38,3	16,2
80(90)+110	14,0	50	85	115	M10x18n.8	45°	12	45,3	39,0
80(90)+130	15,0	60	100	120	M12x21n.8	45°	14	48,8	67,2

5.0 Doppelschneckengetriebe KMGD – Double worm gearboxes KMGD

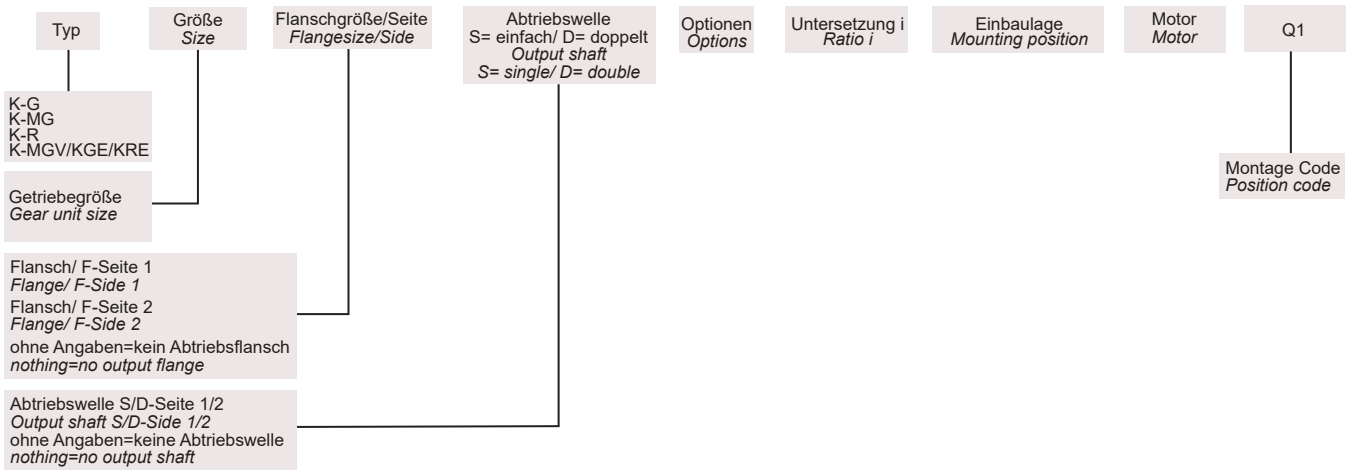

5.1 Montage Code – Position code

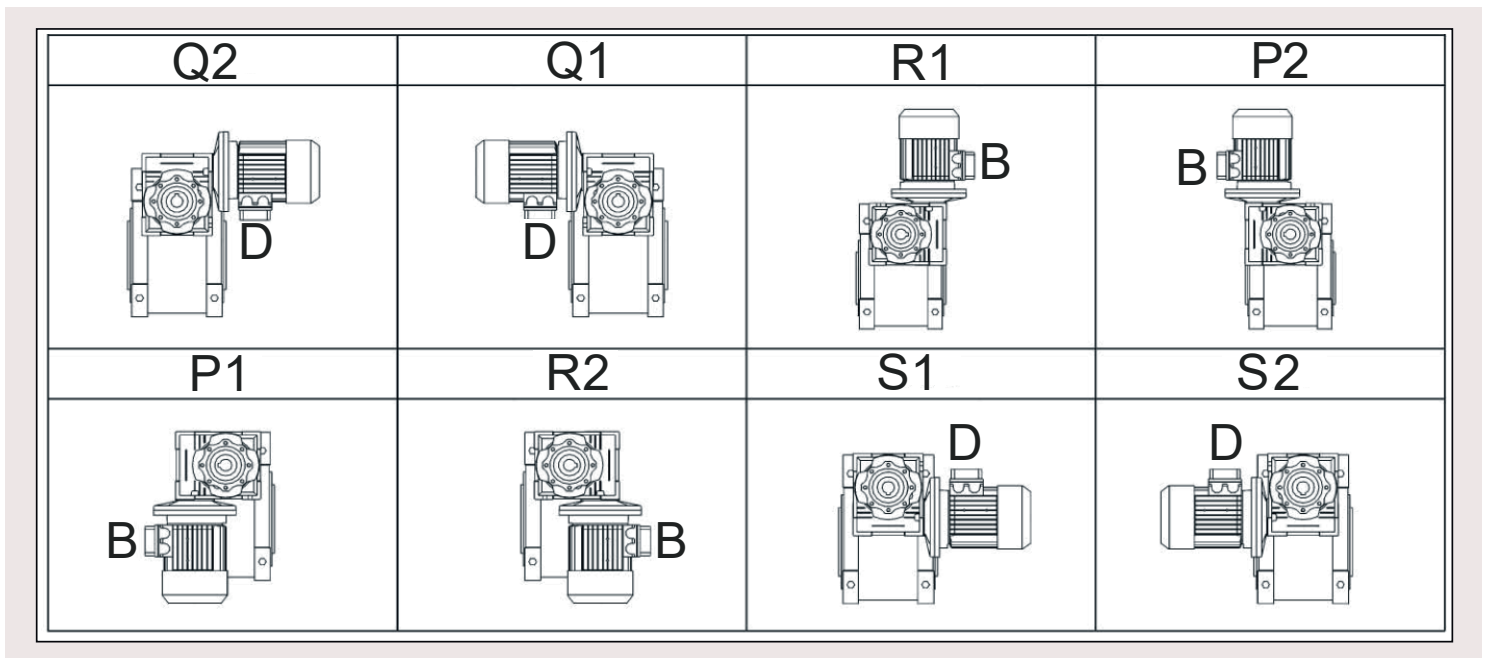

Der Montagecode legt die Position des 1. Getriebes fest. Sollte in der Bestellbezeichnung nichts angegeben werden, so wird das Getriebe in Q1 geliefert. Die angegebene Bauform bezieht sich auf das Abtriebsgetriebe.

The position code specifies the position of the 1st gearbox. Standard combination Q1.

5.2 Daten Doppelschneckengetriebe – Double worm gear selection charts

Bei Antriebsdrehzahl 1400/min / input speed 1400 rpm

	Übersetzung ratio i	Abtriebs- drehzahl output speed n₂	Leistung power kW	Drehmoment torque Nm
K-GD 030/040	300	4.7	0.08	73
	400	3.5	0.06	65
	500	2.8	0.04	61
	600	2.3	0.04	73
	750	1.9	0.04	73
	900	1.6	0.03	73
	1200	1.2	0.02	65
	1500	0.9	0.02	73
	1800	0.8	0.02	73
	2400	0.58	0.01	65
	3200	0.4	0.01	65
	4000	0.4	0.01	33
	5000	0.28	0.01	29
K-GD 030/050	300	4.7	0.15	145
	400	3.5	0.10	124
	500	2.8	0.09	120
	600	2.3	0.08	145
	750	1.9	0.07	145
	900	1.6	0.06	145
	1200	1.2	0.04	124
	1500	0.93	0.04	145
	1800	0.78	0.04	145
	2400	0.6	0.03	124
	3000	0.5	0.02	120
	4000	0.35	0.02	82
	4800	0.29	0.02	82
K-GD 030/063	300	4.7	0.24	230
	400	3.5	0.19	230
	500	2.8	0.15	216
	600	2.3	0.13	230
	750	1.9	0.11	216
	900	1.6	0.09	198
	1200	1.2	0.08	230
	1500	0.93	0.06	216
	1800	0.78	0.05	198
	2400	0.58	0.05	230
	3000	0.47	0.04	216
	4000	0.35	0.03	172
	5000	0.28	0.02	150
K-GD 040/075	300	4.7	0.36	390
	400	3.5	0.27	360
	500	2.8	0.21	320
	600	2.3	0.19	390
	750	1.9	0.16	390
	900	1.6	0.14	390
	1200	1.2	0.11	360
	1500	0.93	0.10	390
	1800	0.78	0.09	390
	2400	0.58	0.07	360
	3000	0.47	0.05	320
	4000	0.35	0.04	250
	5000	0.28	0.03	230

	Übersetzung ratio i	Abtriebs- drehzahl output speed n₂	Leistung power kW	Drehmoment torque Nm
K-GD 040/090	300	4.7	0.56	610
	400	3.5	0.43	610
	500	2.8	0.34	560
	600	2.3	0.30	610
	750	1.9	0.23	560
	900	1.6	0.19	505
	1200	1.2	0.17	610
	1500	0.93	0.14	560
	1800	0.78	0.11	505
	2400	0.58	0.11	610
	3000	0.47	0.08	560
	4000	0.35	0.08	460
	5000	0.28	0.06	410
K-GD 050/110	300	4.7	0.95	1100
	400	3.5	0.69	1030
	500	2.8	0.56	1000
	600	2.3	0.48	1030
	750	1.9	0.43	1100
	900	1.6	0.38	1100
	1200	1.2	0.27	1030
	1500	0.93	0.28	1100
	1800	0.78	0.23	1100
	2400	0.58	0.17	1030
	3000	0.47	0.14	1000
	4000	0.35	0.12	780
	5000	0.28	0.09	710
K-GD 063/130	300	4.7	1.48	1760
	400	3.5	1.09	1650
	500	2.8	0.86	1550
	600	2.3	0.76	1650
	750	1.9	0.66	1760
	900	1.6	0.58	1760
	1200	1.2	0.43	1650
	1500	0.93	0.39	1760
	1800	0.78	0.35	1760
	2400	0.58	0.25	1650
	3000	0.47	0.20	1550
	4000	0.35	0.15	1220
	5000	0.28	0.11	1100
K-GD 063/150	150	9.3	3.4	2340
	200	7.0	2.7	2340
	250	5.6	1.9	2050
	300	4.7	1.9	2340
	400	3.5	1.8	2670
	500	2.8	1.4	2330
	600	2.3	1.3	2670
	750	1.9	0.98	2330
	900	1.6	0.71	2100
	1200	1.2	0.75	2670
	1800	0.8	0.44	2100
	2400	0.6	0.46	2670
	3000	0.5	0.34	2330
4000	0.4	0.23	1880	
5000	0.3	0.18	1650	



5.3 Abmessungen Doppelschneckengetriebe – Double worm gear dimensions

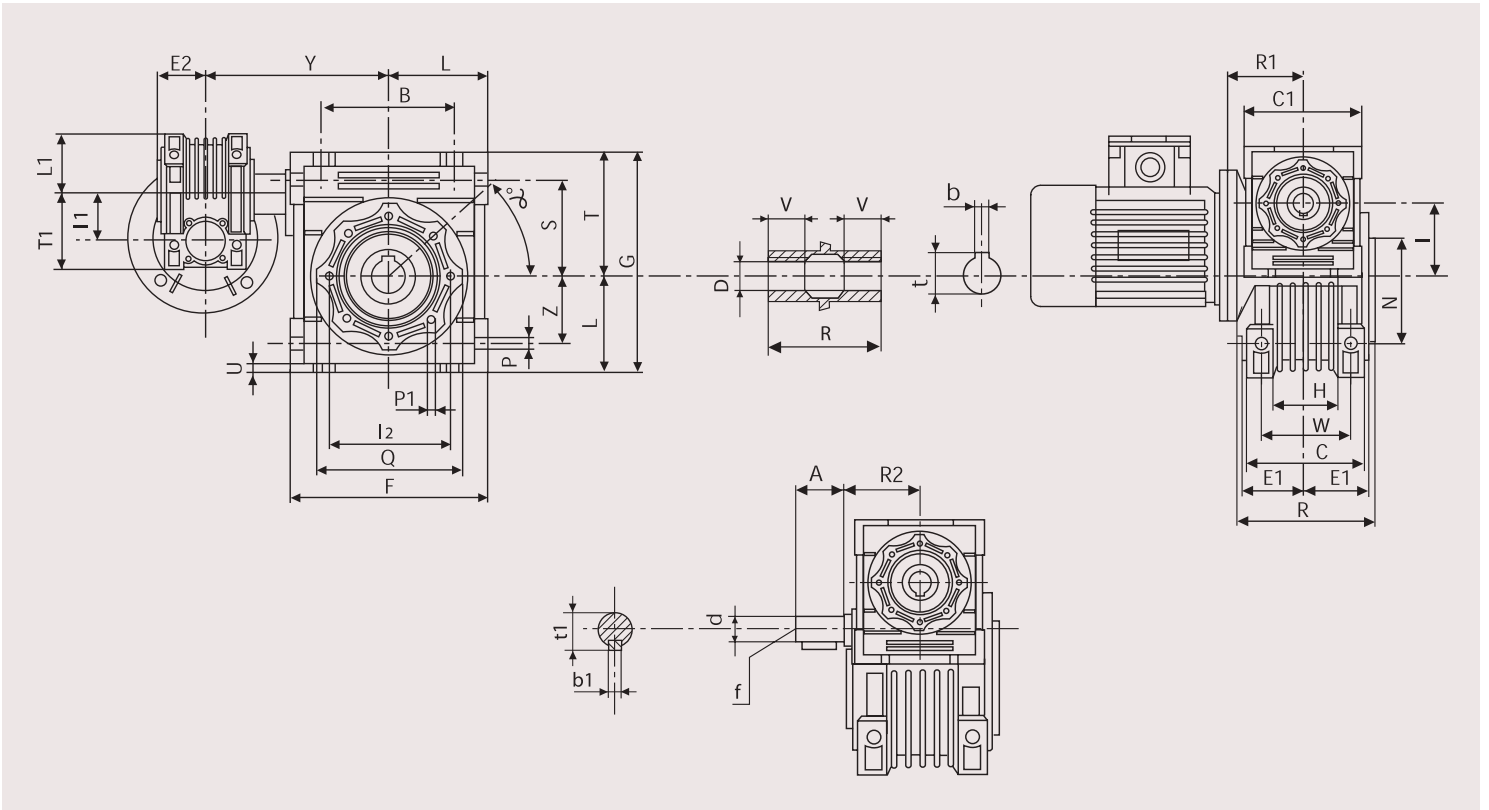

KMGD	B	A	F	C1	D(H7)	d(j6)	G	H	R1	R	R2	L	L1	I	I1	C	I2	N(H8)	E1	E2	P
030/040	70	20	100,0	80	18	9	121,5	43	55	78	51	50,0	40	40	30	71	75	60	36,5	29,0	6,5
030/050	80	20	120,0	80	25	9	144,0	49	55	92	51	60,0	40	50	30	85	85	70	43,5	29,0	8,5
030/063	100	20	144,0	80	25	9	174,0	67	55	112	51	72,0	40	63	30	103	95	80	53,0	29,0	8,5
040/075	120	23	172,0	100	28	11	205,0	72	70	120	60	86,0	50	75	40	112	115	95	57,0	36,5	11,0
040/090	140	23	208,0	100	35	11	238,0	74	70	140	60	103,0	50	90	40	130	130	110	67,0	36,5	13,0
050/110	170	30	252,5	120	42	14	295,0	–	80	155	74	127,5	60	110	50	144	165	130	74,0	43,5	14,0
063/130	200	40	292,5	144	45	19	335,0	–	95	170	90	147,5	72	130	63	155	215	180	81,0	53,0	16,0
063/150	240	40	340,0	144	50	19	400,0	–	95	200	90	170,0	72	150	63	185	215	180	96,0	53,0	18,0

KMGD	Q	S	T	T1	U	V	Z	Y	W	P1	α°	b	b1	f	t	t1	Gewicht in kg ohne Motor
030/040	87	55	71,5	57,0	6,5	26	35	120	60	M6x8(n.4)	45	6	3	–	20,8	10,2	3,9
030/050	100	64	84,0	57,0	7,0	30	40	130	70	M6x10(n.4)	45	8	3	–	28,3	10,2	5,0
030/063	110	80	102,0	57,0	8,0	36	50	145	85	M8x14(n.4)	45	8	3	–	28,3	10,2	7,8
040/075	140	93	119,0	71,5	10,0	40	60	165	90	M8x14(n.4)	45	8	4	–	31,3	12,5	11,5
040/090	160	102	135,0	71,5	11,0	45	70	182	100	M10x18(n.4)	45	10	4	–	38,3	12,5	15,0
050/110	200	125	167,5	84,0	14,0	50	85	225	115	M10x18(n.4)	45	12	5	M6	45,3	16,0	39,2
063/130	250	140	187,5	102,0	15,0	60	100	245	120	M12x21(n.4)	45	14	6	M6	48,8	21,5	70,0
063/150	250	180	230,0	102,0	18,0	72	120	275	145	M12x21(n.8)	45	14	6	M6	53,8	21,5	100,0

6.0 Ersatzteilliste – Sparepartlist

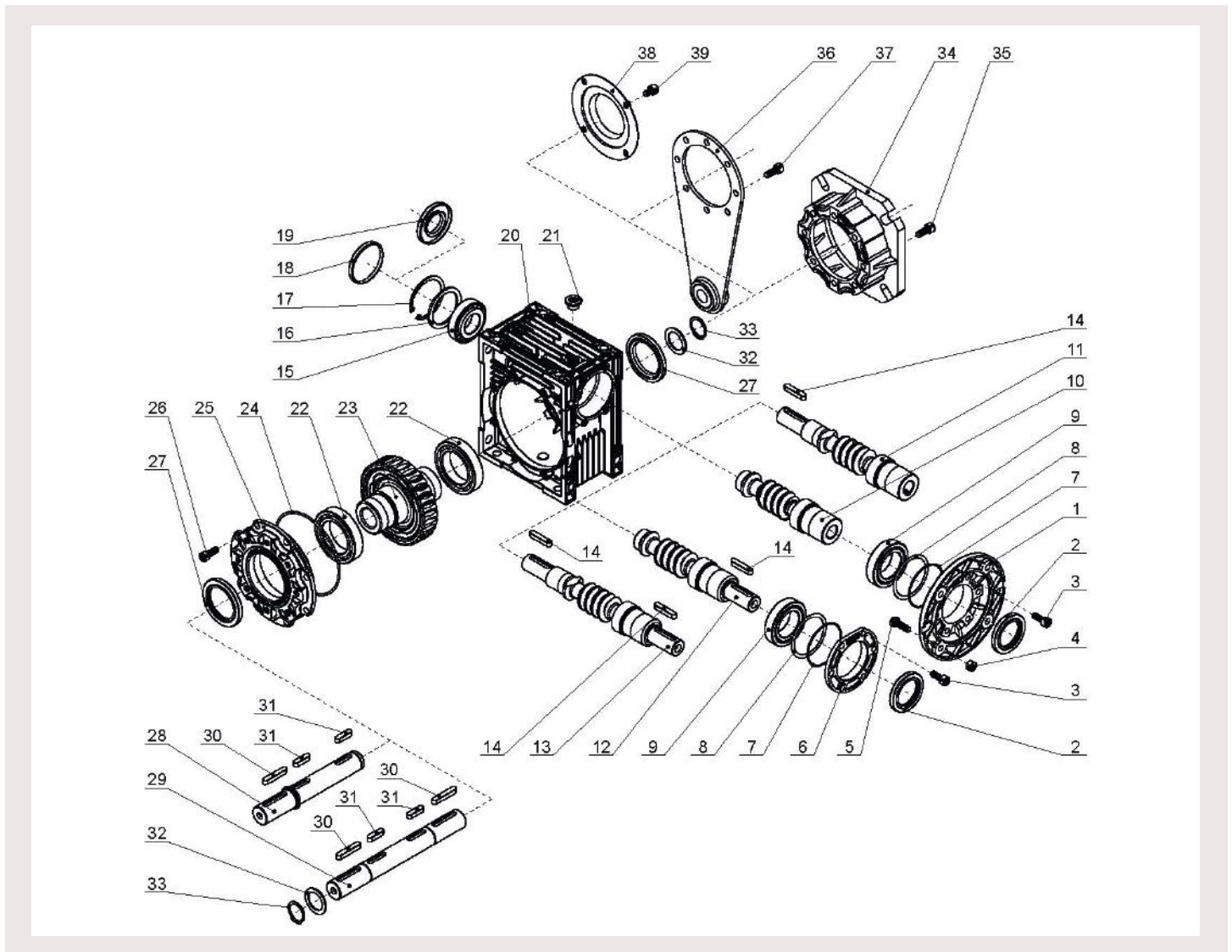

- | | |
|---|--|
| 1 Motorflansch/motor flange | 20 Gehäuse/case |
| 2 Dichtring/oil seal | 21 Ölstopfen/oil plug |
| 3 Inbusschraube/hexagon socket head cap screw | 22 Lager/bearing |
| 4 Mutter/hexagon nuts | 23 Schneckenrad/worm wheel |
| 5 Sechskantschraube/hexagon bolt | 24 O-Ring/o-ring |
| 6 Eingangsflansch/input flange | 25 Gehäusedeckel/case cover |
| 7 O-Ring/o-ring | 26 Inbusschraube/hexagon socket head cap screw |
| 8 Passscheibe/suitable disc | 27 Dichtring/oil seal |
| 9 Lager/bearing | 28 Welle (einseitige Ausgangswelle)/single output shaft |
| 10 Schnecke mit Eingangshohlwelle/input hollow shaft | 29 Welle (doppelseitige Ausgangswelle)/double output shaft |
| 11 Schnecke mit Ausgangswellenzapfen/output shaft tap | 30 Passfeder/key |
| 12 Schnecke mit Eingangswellenzapfen/input shaft tap | 31 Passfeder/key |
| 13 Schnecke mit Wellenzapfen, beidseitig/double shaft tap | 32 Unterlegscheibe/washer |
| 14 Passfeder/key | 33 Seegering/circlip |
| 15 Lager/bearing | 34 Ausgangsflansch/output flange |
| 16 Unterlegscheibe/washer | 35 Inbusschraube/hexagon socket head cap screw |
| 17 Seegering/circlip | 36 Drehmomentstützel/torque arm |
| 18 Abschlussdeckel/cap | 37 Inbusschraube/hexagon socket head cap screw |
| 19 Dichtring/oil seal | 38 Schutzkappe/protection cap |
| | 39 Inbusschraube/hexagon socket head cap screw |

7.0 Planetenverstellgetriebe – Planetary variators

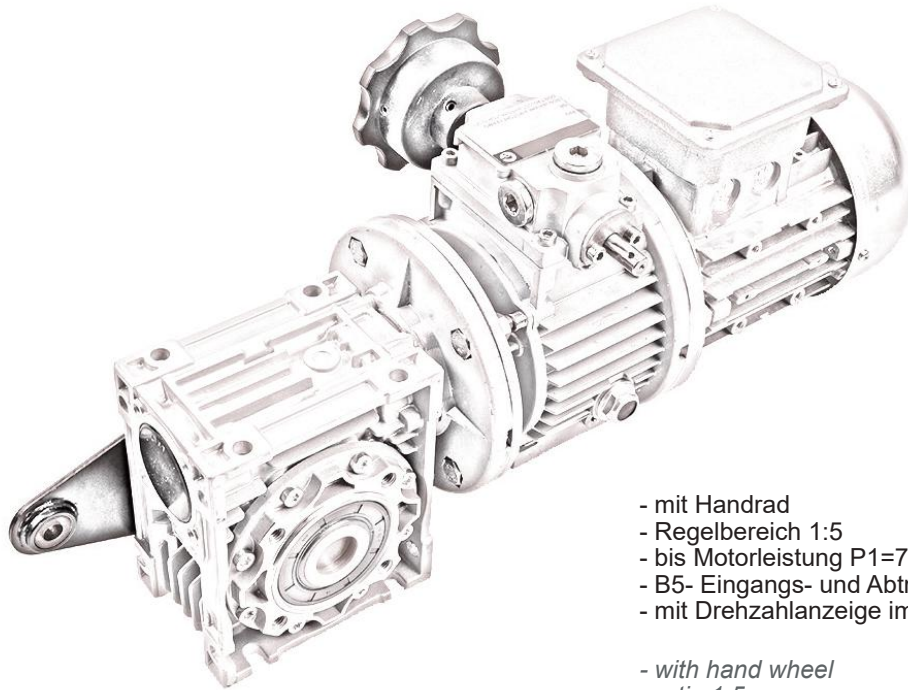

- mit Handrad
 - Regelbereich 1:5
 - bis Motorleistung P1=7,5 kW
 - B5- Eingangs- und Abtriebsflansche
 - mit Drehzahlanzeige im Handrad lieferbar
-
- with hand wheel
 - ratio 1:5
 - input power up to 7,5 kW
 - input and output flange
 - option: with speed control in hand wheel

V 63-132

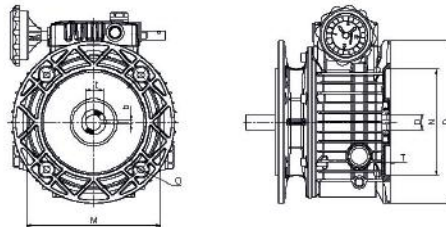

	P	N	M	O	D	b
V 63	140	95	115	M8	11	4
V 71	160	110	130	M8	14	5
V 80	200	130	165	M10	19	6
V 90	200	130	165	M10	24	8
V 100/112	250	180	215	M12	28	8
V 132	300	230	265	M12	38	10

Die mechanischen Verstellgetriebe sind bei der Lieferung mit Schmiermittel befüllt. Ohne Angabe der Einbaulage wird das Getriebe für den waagerechten Einbau mit Öl befüllt. Bitte beachten Sie immer die Einbaulage der Regeleinheit; Ölfüllung, Ablass-, Entlüftungs- und Ölschauglas muss nach Einbaulage angepasst werden. Die Ölfüllmenge muss immer bis zur Hälfte des Ölschauglases sichtbar sein. Bitte prüfen Sie dies nur während des Stillstands. Nach den ersten 100 Betriebsstunden und jeweils nach 1000 Stunden sollte ein Ölwechsel durchgeführt werden.

The variators are filled with lubricant on delivery. If the installation position is not specified, the gear unit is filled with oil for horizontal installation. Please always observe the installation position of the control unit; Oil filling, drain, venting and oil sight glass must be adjusted according to installation position. The oil filling quantity must always be visible up to half of the oil sight glass. Please only check this during standstill. After the first 100 hours of operation and in each case after 1000 hours an oil change should be done.

8.0 Aluminium IEC Motor – Aluminium IEC motor

Drehstrommotor

- 1) 230/400V + 400/690V 50Hz
- 2) Isolationsklasse F
- 3) S1-Betrieb
- 4) Schutzart IP55 → 69k
- 5) IE1 → IE4

Three-phase-motor

- 1) 230/400V + 400/690V 50Hz
- 2) Class F insulation
- 3) S1 duty
- 4) IP55 → 69k protection
- 5) IE1 → IE4

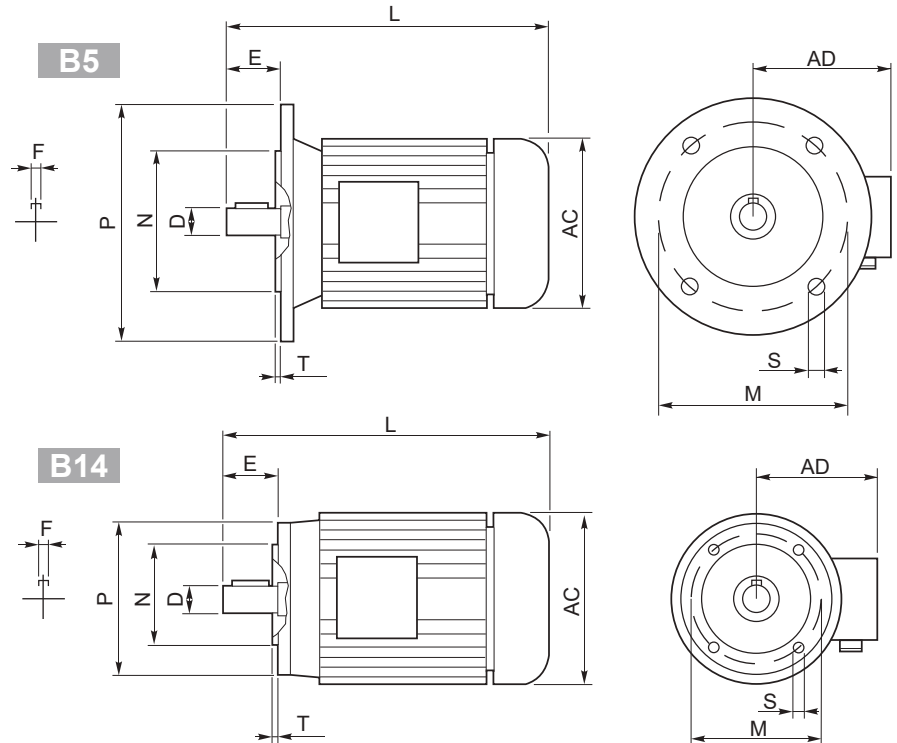

Abmaße und Gewicht können je nach Hersteller variieren

Outside dimensions and weight may be different according to manufacturers.

	2 pol. / poles			4 pol. / poles			6 pol. / poles			B5-B14					B5					B14					Kg	
	kW	Nm	A _(400V)	kW	Nm	A _(400V)	kW	Nm	A _(400V)	D	F	E	L	AC	AD	N	M	P	S	T	N	M	P	S		T
56 A	0.09	0.32	0.38	0.06	0.44	0.27	—	—	—	9	3	20	199	108	96	80	100	120	7	2.5	50	65	80	M5	2.5	2.7
56 B	0.12	0.42	0.46	0.09	0.67	0.37	—	—	—																	2.9
63 A	0.18	0.63	0.60	0.12	0.84	0.50	0.09	0.99	0.57	11	4	23	208	120	99	95	115	140	9.5	3	60	75	90	M5	2.5	3.8
63 B	0.25	0.87	0.76	0.18	1.30	0.69	0.12	1.32	0.74																	4.2
71 A	0.37	1.30	1.00	0.25	1.70	0.91	0.18	1.90	0.80	14	5	30	-	130	104	110	130	160	9.5	3.5	70	85	105	M6	2.5	5.9
71 B	0.55	1.90	1.54	0.37	2.52	1.14	0.25	2.72	1.10				255	141	107											6.5
80 A	0.75	2.60	1.85	0.55	3.77	1.51	0.37	3.84	1.18	19	6	40	296	159	127	130	165	200	11.5	3.5	80	100	120	M6	3	8.5
80 B	1.1	3.90	2.64	0.75	5.11	2.57	0.55	5.84	1.80																	10
90 S	1.5	5.00	3.31	1.1	7.45	2.78	0.75	7.92	2.32	24	8	50	-	170	135	130	165	200	11.5	3.5	95	115	140	M8	3	12.5
90 L	2.2	7.50	4.46	1.5	10.2	3.61	1.1	11.6	3.45				330													15
100 LA	3.0	10.0	6.28	2.2	14.8	5.07	1.5	15.4	3.88																	20
100 LB	—	—	—	3.0	20.1	6.66	—	—	—	28	8	60	-	190	148	180	215	250	13	4	110	130	160	M8	3.5	22
112 M	4.0	13.4	8.10	4.0	26.7	8.55	2.2	22.6	5.30				381	210	164											35
132 S	5.5	18.3	11.2	5.5	36.5	11.4	3.0	30.2	7.20				455													41
	7.5	24.9	15.3							38	10	80		244	180	230	265	300	14	4	130	165	200	M10	4	51
132 M	—	—	—	7.5	49.4	15.0	4.0	40.0	9.13				500													51
				9	61.4	18.5																				
160 M	—	—	—	11	72	21.5	—	—	—	42	12	110	613	335	246	250	300	350	18	5	—	—	—	—	—	79.2
160 L	—	—	—	15	98	29	—	—	—				657													97.5
180 M	—	—	—	18.5	121	35.5	—	—	—	48	14	110	712	366	266	250	300	350	19	5	—	—	—	—	—	170
180 L	—	—	—	22	144	42	—	—	—																	
200 L	—	—	—	30	196	53	—	—	—	55	16	110	780	405	341	300	350	400	19	5	—	—	—	—	—	240
225 S	—	—	—	37	240	69	—	—	—	60	18	140	888	463	360	350	400	450	19	5	—	—	—	—	—	305
225 M	—	—	—	45	292	84	—	—	—																	310



9.0 Spannungsversorgung weltweit – Power supply worldwide

Land	f (Hz)	Spannung	Land	f (Hz)	Spannung	Land	f (Hz)	Spannung
Afghanistan	50 Hz	220 / 380 V	Honduras	60 Hz	110 / 220 V	Panama	60 Hz	120 / 240 V
Ägypten	50 Hz	220 / 380 V	Hongkong	50 Hz	220 / 346 V	Paraguay	50 Hz	220 / 380 V
Albanien	50 Hz	220 / 380 V			202 / 415 V	Peru	60 Hz	220 / 380 V
Algerien	50 Hz	127 / 220 V	Indien	50 Hz	230 / 400 V	Philippinen	60 Hz	125 / 216 V
		230 / 400V	Indonesien	50 Hz	127 / 220 V	Polen	50 Hz	220 / 380 V
Angola	50 Hz	220 / 380 V			230 / 400V	Portugal	50 Hz	230 / 400 V
Argentinien	50 Hz	220 / 380 V	Irak	50 Hz	220 / 380 V	Puerto Rico	50 Hz	120 / 230 V
Australien	50 Hz	240 / 415 V	Iran	50 Hz	220 / 380 V	Rhodesien	50 Hz	220 / 380 V
Äthiopien	50 Hz	220 / 380 V	Irland	50 Hz	220 / 380 V	Rumänien	50 Hz	220 / 380 V
Azoren (Portugal)	50 Hz	220 / 380 V	Island	50 Hz	220 / 380 V	Ruanda	50 Hz	230 / 400 V
Bahamas	60 Hz	120 / 240 V	Israel	50 Hz	220 / 380 V	Rußland	50 Hz	220 / 380 V
		120 / 208 V	Italien	50 Hz	230 / 400V	Saudi Arabien	60 Hz	127 / 220 V
Bahrain	50 Hz	230 / 400 V	Jamaika	50 Hz	110 / 220 V	Schweden	50 Hz	230 / 400 V
	60 Hz	110 / 115 V	Japan	60 Hz	100 / 200 V	Schweiz	50 Hz	230 / 400 V
Bangladesh	50 Hz	220 / 440 V		50 Hz	100 / 200V	Senegal	50 Hz	127 / 220 V
Barbados	50 Hz	115 / 230 V	Jordanien	50 Hz	220 / 380 V	Serbien / Montenegro	50 Hz	220 / 380 V
		115 / 200 V	Kambodscha	50 Hz	120 / 208 V	Seychellen	50 Hz	240 / 450 V
Belgien	50 Hz	230 / 400 V			220 / 380 V	Sierra Leone	50 Hz	230 / 400 V
Bermuda	60 Hz	120 / 240 V	Kamerun	50 Hz	220 / 380 V	Singapore	50 Hz	230 / 400 V
		120 / 208 V	Kazakstan	50 Hz	220 / 380 V	Slovakische Republik	50 Hz	220 / 380 V
Bolivien	50 Hz	110 / 220 V	Kenia	50 Hz	240 / 415 V	Somalia	50 Hz	220 / 380 V
		220 / 380 V	Kolumbien	60 Hz	110 / 220 V	ehem. Sowjetunion	50 Hz	220 / 380 V
Botswana	50 Hz	220 / 380 V			150 / 260 V	Spanien	50 Hz	220 / 380 V
		230 / 400 V	Kongo	50 Hz	220 / 380 V	Sri Lanka	50 Hz	230 / 400 V
Brasilien	60 Hz	110 / 220V	Korea	60 Hz	100 / 200 V	Südafrika	50 Hz	230 / 400 V
		220 / 380V			220 / 380 V	Sudan	50 Hz	240 / 415 V
Bulgarien	50 Hz	220 / 380 V	Kuwait	50 Hz	240 / 415 V	Surinam	60 Hz	127 / 220 V
Burkina Faso	50 Hz	220 / 380 V	Laos	50 Hz	220 / 380 V	Swasiland	50 Hz	230 / 400 V
Burma	50 Hz	223 / 400 V	Lesotho	50 Hz	220 / 380 V	Syrien	50 Hz	220 / 380 V
Burundi	50 Hz	220 / 380 V	Libanon	50 Hz	220 / 380V	Tahiti	60 Hz	127 / 220 V
Canada	60 Hz	120 / 240 V	Libyen	50 Hz	127 / 220 V	Taiwan	60 Hz	110 / 220 V
Cape Verde	50 Hz	220 / 380 V	Luxemburg	50 Hz	230 / 400 V	Tansania	50 Hz	220 / 380 V
Cayman Inseln	60 Hz	120 / 240 V	Macao	50 Hz	220 / 380 V	Thailand	50 Hz	220 / 380 V
Chad	50 Hz	220 / 380 V	Madagascar	50 Hz	200 / 345 V	Togo	50 Hz	220 / 380 V
Chile	50 Hz	220 / 380 V	Malaysia	50 Hz	240 / 415 V	Trinidad / Tobago	60 Hz	115 / 230 V
China VR	50 Hz	220 / 380 V	Malawi	50 Hz	230 / 400V			230 / 400 V
Costa Rica	60 Hz	120 / 240 V	Malediven	50 Hz	230 / 400V	Tschechien	50 Hz	230 / 400 V
Dahome	50 Hz	220 / 380 V	Mali	50 Hz	220 / 380 V	Tunesien	50 Hz	127 / 220 V
Dänemark	50 Hz	230 / 400 V	Malta	50 Hz	240 / 415 V			230 / 400 V
Deutschland	50 Hz	230 / 400 V	Mauritanien	50 Hz	220 / 380 V	Türkei	50 Hz	230 / 400 V
Djibouti	50 Hz	220 / 380 V	Martinique	50 Hz	230 / 400V	Turkmenistan	50 Hz	230 / 400 V
Dom. Republik	60 Hz	110 / 220 V	Marokko	50 Hz	127 / 220 V	Uganda	50 Hz	240 / 415 V
Ecuador	60 Hz	120 / 208 V	Mexiko	60 Hz	127 / 220 V	Ukraine	50 Hz	220 / 380 V
El Salvador	60 Hz	115 / 230 V	Monaco	50 Hz	127 / 220 V	Ungarn	50 Hz	230 / 400 V
England	50 Hz	230 / 415 V			220 / 380 V	Uruguay	50 Hz	220 / 380 V
Eritrea	50 Hz	220 / 380 V	Mongolei	50 Hz	230 / 400 V	Uzbekistan	50 Hz	220 / 380 V
Fidji	50 Hz	220 / 415 V	Mozambique	50 Hz	220 / 380 V	USA	60 Hz	115 / 200 V
Finnland	50 Hz	230 / 400 V	Namibia	50 Hz	220 / 380 V	Venezuela	60 Hz	120 / 240 V
Frankreich	50 Hz	230 / 400 V	Nepal	50 Hz	220 / 380 V			127 / 220 V
Gambia	50 Hz	228 / 380 V	Neuseeland	50 Hz	230 / 400 V	Vietnam	50 Hz	220 / 380 V
Ghana	50 Hz	240 / 400 V	Niederlande	50 Hz	230 / 400 V	Verein. Arab.Emirate	50 Hz	220 / 380 V
Grenada	50 Hz	230 / 400 V	Nicaragua	50 Hz	120 / 240 V	Zentralafrikan. Rep.	50 Hz	220 / 380 V
Gibraltar	50 Hz	240 / 415 V	Niger	50 Hz	220 / 380 V	Zypern	50 Hz	240 / 415 V
Griechenland	50 Hz	230 / 400 V	Nigeria	50 Hz	220 / 380 V	Zimbabwe	50 Hz	220 / 380 V
Grönland	50 Hz	220 / 380 V	Norwegen	50 Hz	230 / 400 V			
Guatemala	60 Hz	120 / 240 V	Obervolta	50 Hz	220 / 380 V			
Guinea	50 Hz	220 / 380 V	Oman (Muscat)	50 Hz	240 / 415 V			
Guyana	50 Hz	110 / 220 V	Österreich	50 Hz	230 / 400 V			
Haiti	60 Hz	110 / 220 V	Pakistan	50 Hz	230 / 400 V			

Diese Angaben sind unverbindlich.



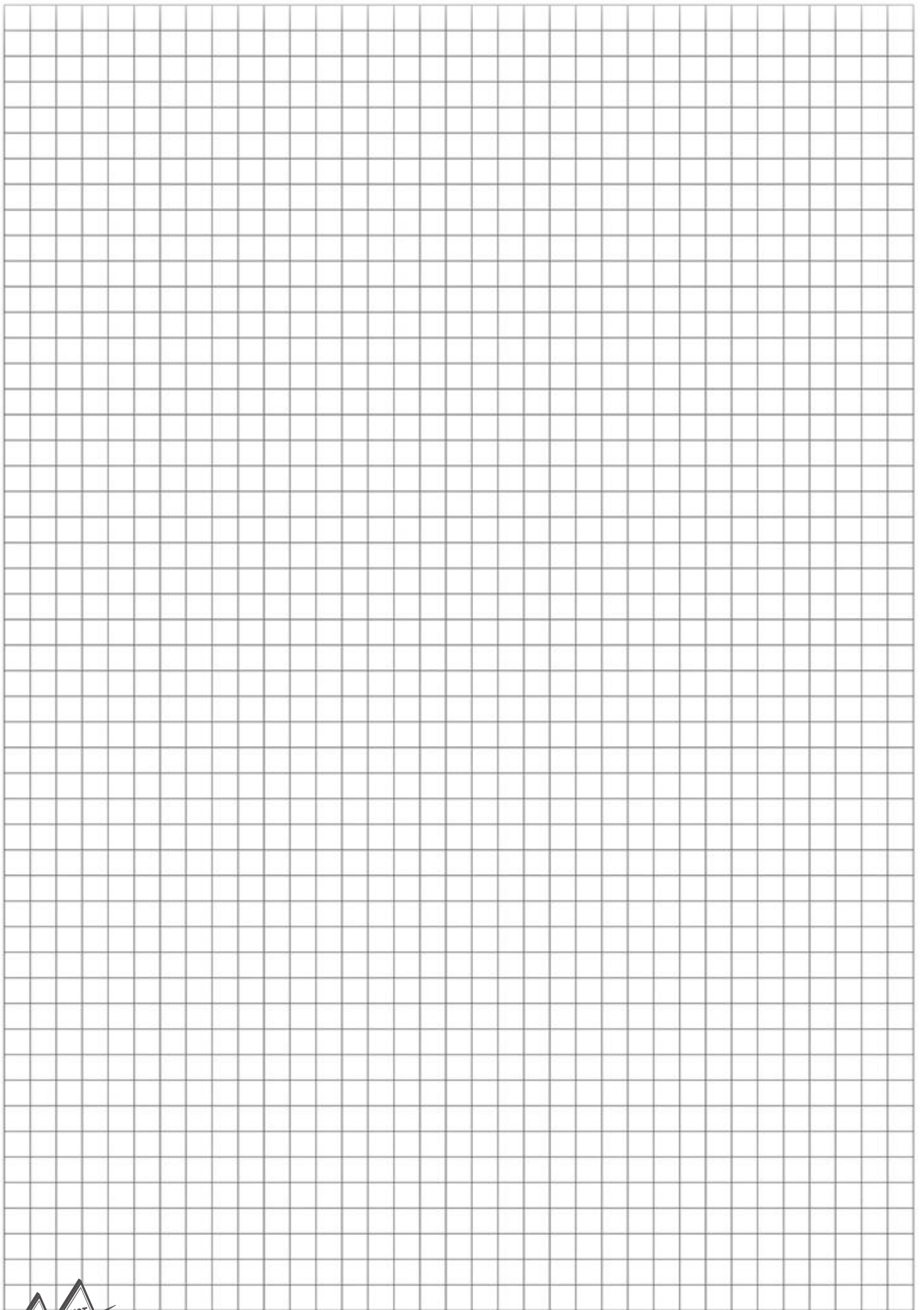

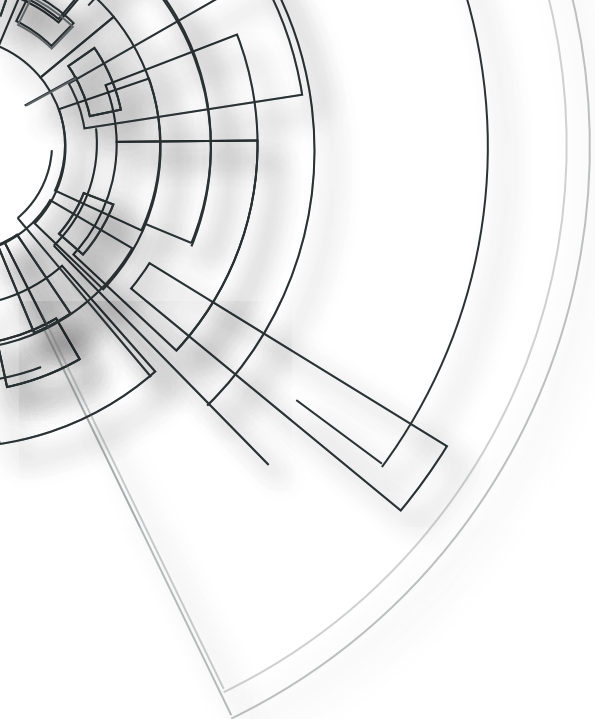

*Produkte können von den Abbildungen abweichen. Änderungen und Irrtümer vorbehalten.
Keine Haftung für Druckfehler oder technische Angaben.
Products may deviate from the images. Changes and errors expected.
No liability for printing errors or technical specifications.*





Wir engagieren uns gerne für Sie.
We´re here to help.

GEMOTEG GmbH & Co. KG

Walkenmühleweg 49
D-72379 Hechingen
phone. +49 7471 93010-30
fax. +49 7471 93010-59
info@gemoteg.de
www.gemoteg.de

Schneckengetriebe | Verstellgetriebe | Elektromotoren
Worm gears | Speed variators | Electric motors

Drives & Systems